



**LEEP**

LOCAL ENERGY  
EFFICIENCY  
PARTNERSHIPS

NET ZERO  
ENERGY

# Wall Assembly #1

Split-Wall: Vapour Permeable Exterior Insulation

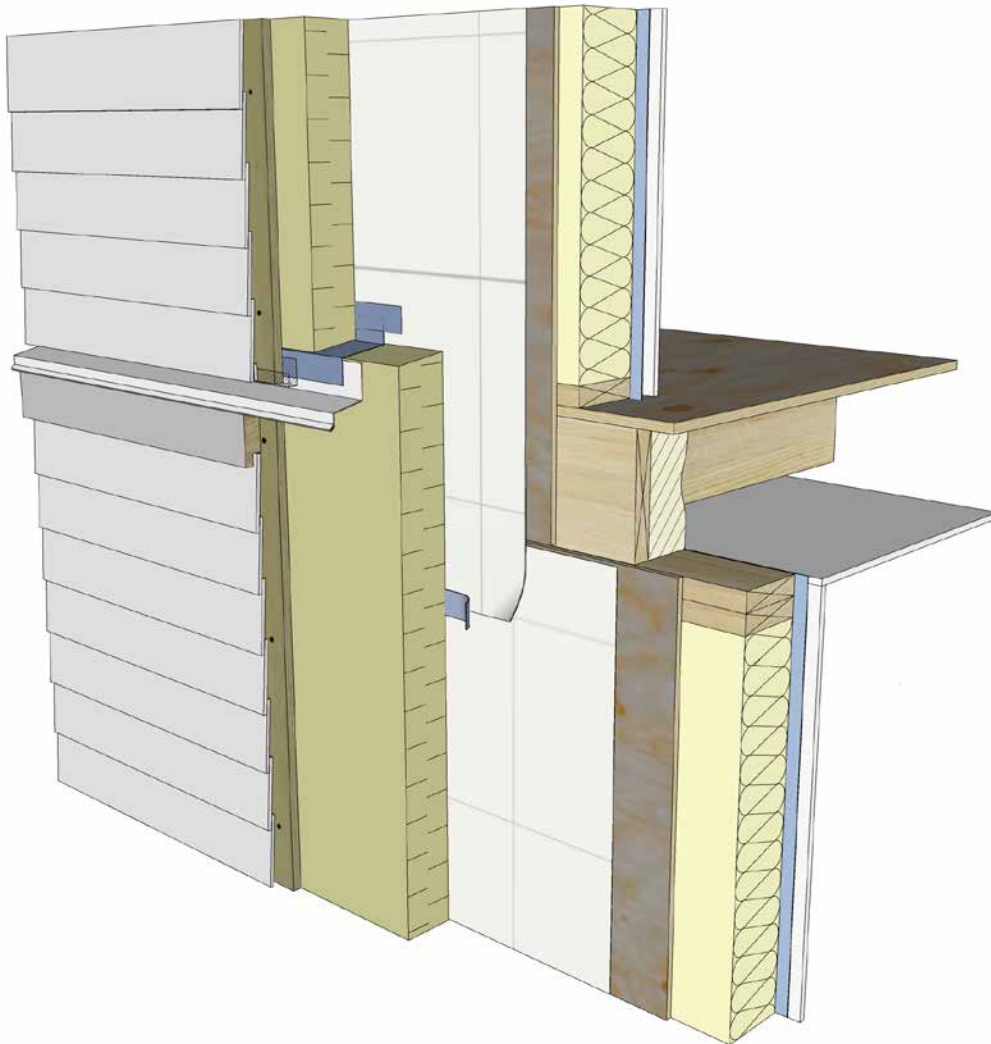

Developed by Natural Resources Canada's  
Local Energy Efficiency Partnerships (LEEP) team

**LEEP Net Zero Energy Wall Assembly #1**  
**Split-Wall: Vapour Permeable Exterior Insulation**

M154-165/1-2024E-PDF (On-line) ISBN 978-0-660-70701-3  
(Set) M154-165/2024E-PDF ISBN 978-0-660-70699-3

Aussi disponible en français sous le titre:

«LEEP ENZ Assemblage du mur #1 Mur divisé : Isolation extérieure perméable à la vapeur d'eau»  
Copyright © His Majesty the King in Right of Canada, as represented by the Minister of Natural Resources, 2024

## Acknowledgements

The *Local Energy Efficiency Partnerships* (LEEP) team at CanmetENERGY would like to thank the many Canadian builders who have participated in our programs. Builders were contacted by their regional Home Builders Associations and invited to participate in LEEP technical forums and workshops. Their feedback identified the need for this series of guides. Builder groups repeatedly requested technical forums on high-performance above-grade wall assemblies and focused on four commonly used, generic wall assemblies. These wall assemblies were studied by building science experts and manufacturers and were upgraded for energy efficiency and for use in net zero buildings. Response to the resulting presentations has been positive and builders have gone on to trial these wall assemblies.

We would like to thank RDH Building Science for their work in developing and illustrating the guides, updating them based on broad feedback, and developing the technical presentations for LEEP initiatives that provided the foundation for this work. We would also like to thank Morrison Hershfield for providing a technical and code review.

We want to acknowledge the essential contribution made by our partners and their help in delivering regional and local LEEP initiatives that led to this guide series. These partners include: BC Housing, BC Hydro, FortisBC, BCIT, the Nova Scotia Ministry of Energy and Mines, and Efficiency Nova Scotia. We would particularly like to thank the provincial and local Home Builders Associations that made this possible, including CHBA British Columbia, HAVAN, CHBA Central Okanagan, CHBA Central Interior, CHBA Northern BC, CHBA Vancouver Island, CHBA Kelowna, CHBA Fraser Valley, CHBA New Brunswick, CHBA Nova Scotia, and CHBA Newfoundland.

The LEEP NZE Wall Guide Series was developed by Graham Finch and James Higgins of RDH Building Science. Project management was provided by Clarice Kramer with support from James Glouchkow and Patric Langevin of the NRCan LEEP Team, CanmetENERGY Ottawa. Funding for this work was provided by *Natural Resources Canada* through the *Green Infrastructure Fund*.

## Disclaimer

This document does not provide assurances or information related to structural systems, seismic performance, or fire safety. It is intended only as a guide on building enclosure science and wall assembly selection, detailing, materials and performance. The aim of this publication is to provide builders and designers with a framework for making decisions on the type of wall assemblies to use for individual homes and for new communities.

Natural Resources Canada assumes no liability for injury, property damage, or loss resulting from the use of information contained in this publication. This guide is intended to provide information only and does not express views of the Government of Canada nor does it constitute an endorsement of any commercial product, manufacturer or any individual.

Building science, related products, and construction practices change and improve over time, and it is advisable to regularly consult up-to-date technical publications on building science, products, and practices rather than relying solely on this publication. Seek specific information on the use of products, the requirements of good design and construction practices, and requirements of the applicable building codes before undertaking a construction project. Consult the manufacturer's instructions for construction products, and also speak with and retain professional consultants who hold a valid license and have appropriate engineering or architectural qualifications. Work with your municipality or local authority having jurisdiction to ensure compliance with issues of design, zoning and construction practices, including life and fire safety.

The effective R-value ranges and assemblies illustrated in this guide represent potential strategies to reach high-performance targets including the upper tiers of the National Building Code of Canada. As with any performance-based energy target, energy modelling must be used to determine appropriate designs for each individual project. Compliance strategies may be influenced by design choices such as building form, window placement, orientation, mechanical systems, and equipment efficiency.

The information included in these guides is generic in nature and is not tied to any specific voluntary labeling program. Builders and renovators looking to qualify their homes under the Canadian Home Builders' Association (CHBA) *Net Zero Home Labeling Program* must ensure their homes meet all the Technical Requirements of that Program.

## LEEP Context

The LEEP Team at CanmetENERGY works with groups of builders, through their Home Builders Associations (HBAs). LEEP programs offer opportunities to identify barriers and gaps in technology and to discuss and evaluate Net Zero Energy (NZE) and high-performance home building strategies. Builders use forums and workshops to identify key technology challenges and invite experts and manufacturers to respond by proposing solutions, innovations and direction on how to integrate these ideas into construction practices. Through their HBAs, builders use LEEP to define and solve technology challenges, and to connect with design professionals who can help them deliver the homes of tomorrow. The goal is builder-driven enhancement to local building practices.

## The Need

There is a need for fundamental change in wall design and construction. Canadian builders are moving beyond typical wood-framing practices to wall assemblies that reach higher levels of performance. LEEP technical forums have been delivered in many locations across Canada. Regional LEEP builder-groups have consistently identified high-performance walls as a key technological challenge. They have requested information on:

- › Increased effective R-values; continuous insulation and reduced thermal bridging
- › Continuous air barrier and airtight building enclosures; improved thermal performance, reduced heating and cooling loads, reduced risk of condensation within wall cavities
- › Water-protection systems; reduced risk of bulk water intrusion from rain, snow and wind, reliable water-shedding details
- › Effective vapour barrier; reduced risk of trapping moisture within the wall assembly, assurance that double vapour barriers are not created

There is great diversity in Canadian light wood construction. Wall details and assembly types vary by region and climate zone. Local construction practices can also vary, along with access to reliable technical information and training. Coordination with trades and consultants is critical when introducing new technology and this should not be overlooked. It is our hope that by providing these guidelines for wall assemblies with construction details, we will help builders select, plan and construct robust wall assemblies with success. Project-specific details should always be developed to account for the unique conditions of each project.

We see the LEEP NZE Wall Guides not as the end goal, but as part of the foundation for a new generation of high-performance housing.

## Documents in This Series

Further to the guidance presented in the wall guides, Appendix A and B present guidance on material and product selection for each assembly. The following is a list of the documents in the NRCan LEEP Net Zero Energy Wall Assembly Technical Guide series:

- YOU ARE HERE**
- › **Introduction:** LEEP NZE Wall Guide Series & The Wall Selection Guide
  - ➔ **Wall #1** Split-Wall: Vapour Permeable Exterior Insulation
  - › **Wall #2** Split-Wall: Wood Fibre Exterior Insulation
  - › **Wall #3** Split-Wall: Low-Permeance Exterior Insulation
  - › **Wall #4** Double Stud Wall with Interior Service Wall
  - › **Appendix A:** Building Material and Product Selection Guide
  - › **Appendix B:** Selection Process for Exterior Insulation in Split-Walls

This guide-series examines four generic above grade wall assemblies. Builders, from different regions in Canada, repeatedly selected these common wall types in LEEP workshops and asked for technical guidance on modifications and performance upgrades.

## Contents

Preface . . . . .	9
Overview of Wall Assembly #1 . . . . .	9
Design Considerations . . . . .	12
Exterior Insulation, Strapping & Cladding . . . . .	15
Window Installation. . . . .	22
Structural Requirements & Fastener Tables . . . . .	26
Wall Air Barrier Systems . . . . .	28
Typical Construction Details . . . . .	32
Builder Checklist for Net Zero Wall Construction . . . . .	44

## List of Figures

Figure 1 Split-insulated wall with exterior vapour permeable rigid insulation . . . . .	9
Figure 2 Typical assembly layers of the split-insulated wall with exterior vapour permeable rigid insulation . . . . .	10
Figure 3 Wall #1 effective R-values table . . . . .	11
Figure 4 Fasteners through insulation . . . . .	12
Figure 5 Exterior insulation serves to increase the temperature of the wood sheathing, which reduces the potential for condensation within the assembly. Thicker exterior insulation further minimizes this risk. Permeable exterior insulation allows any moisture that may enter the wall to dry outwards and does not trap it. . . . .	13
Figure 6 Exterior insulation installation method . . . . .	15
Figure 7 Examples of optimized strapping layout . . . . .	17
Figure 8 Conventional through-wall flashing detail and strapping installation . . . . .	18
Figure 9 Simplified through-wall flashing approach (without positive laps) . . . . .	18
Figure 10 Through-wall flashing installation: metal flashing installed with screws at the front face of the exterior insulation, flashing membrane installed over lower insulation and adhered to metal flashing, and upper strapping used to secure flashing in place. . . . .	20
Figure 11 Preservative-treated deflection blocks installed at the top edge of the flashing can be used to limit deflection and support heavier-weight claddings if needed. . . . .	21
Figure 12 Screws installed at an upward angle can be used to limit deflection and support heavier-weight claddings if needed. . . . .	21
Figure 13 Wider corner strapping installation where corner trim must be installed onto strapping. . . . .	22
Figure 14 Cross-strapping is used to produce a horizontal strapping substrate for vertical cladding. . . . .	22
Figure 15 In dry climates with no rainscreen requirements, horizontal strapping alone can be used. . . . .	22
Figure 16 Examples of window sill membrane installation at the rough opening . . . . .	23
Figure 17 Window rough opening membrane installation at the sill, jamb and head. . . . .	23

Figure 18	Sill drainage options (exterior insulation and cladding not shown for clarity).	23
Figure 19	Window rough opening air and water sealing options	24
Figure 20	Window head flashing with taped through-wall flashing membrane.	25
Figure 21	Window head flashing with through-wall flashing membrane lapped beneath the field membrane.	25
Figure 22	Window head flashing installed at the front face of the exterior insulation with secondary flashing installed directly above window.	25
Figure 23	Window head flashing installed at the front face of the strapping with secondary flashing installed directly above window.	25
Figure 24	Design aspects of the strapping and fastener installation	26
Figure 25	Mechanically fastened sealed sheathing membrane, with all edges of the airtight material taped.	28
Figure 26	Vapour permeable self-adhered sheathing membrane, with all edges fully adhered to itself and the substrate to create an airtight layer.	28
Figure 27	Sealed exterior sheathing air barrier approach.	29
Figure 28	Liquid applied air barrier membrane	29
Figure 29	Example air barrier lines of continuity across the entire building enclosure and including all transition details.	30
Figure 30	Common sheathing membrane and ceiling air barrier deficiencies.	31
Figure 31	Example airtightness sign to use on site for notifying all staff and trades.	31

## List of Construction Details

Detail 1.01	Wall Section Overview & Materials	34
Detail 1.02	Wall Section Details Wayfinder	35
Detail 1.03	Base of Wall at Foundation	36
Detail 1.04	Cladding Transition at Floor Line	37
Detail 1.05	Wall & Roof Interface	38
Detail 1.06	Window Sill	39
Detail 1.07	Window Jamb	40
Detail 1.08	Window Head	41
Detail 1.09	Wall Penetration at Duct - Section	42
Detail 1.10	Wall Penetrations at Receptacle - Section	43



## Preface

There is a need for a fundamental change in wall design, detailing and construction. To reach Net Zero Energy (NZE) levels of performance in homes and multi-family buildings, builders need to achieve superior levels of airtightness and higher effective insulation levels in walls. This means reduced air leakage, higher levels of insulation and reduced thermal bridging. This guide series is intended to establish common wall assembly designs that the industry can use or modify for building NZE housing. It does not provide information related to structural systems, seismic performance, or fire safety.

## Overview of Wall Assembly #1

This above-grade wall assembly consists of multiple layers of rigid or semi-rigid mineral wool insulation placed on the exterior of a conventional insulated wood-frame wall assembly. High effective R-values are achieved by using layers of continuous vapour permeable insulation outside of the structural framing and low-conductivity cladding attachments, in combination with insulation in the stud space. In most cases, cladding can be supported by strapping fastened with screws through rigid insulation.

The vapour permeable exterior insulation product used in this arrangement should not be sensitive to moisture as it will be exposed to periodic wetting. In cold climates, insulation placed on the exterior of the stud wall increases the temperature of the moisture-sensitive wood sheathing and framing and consequently often improves the durability of the assembly by reducing the risk of condensation and associated moisture damage.

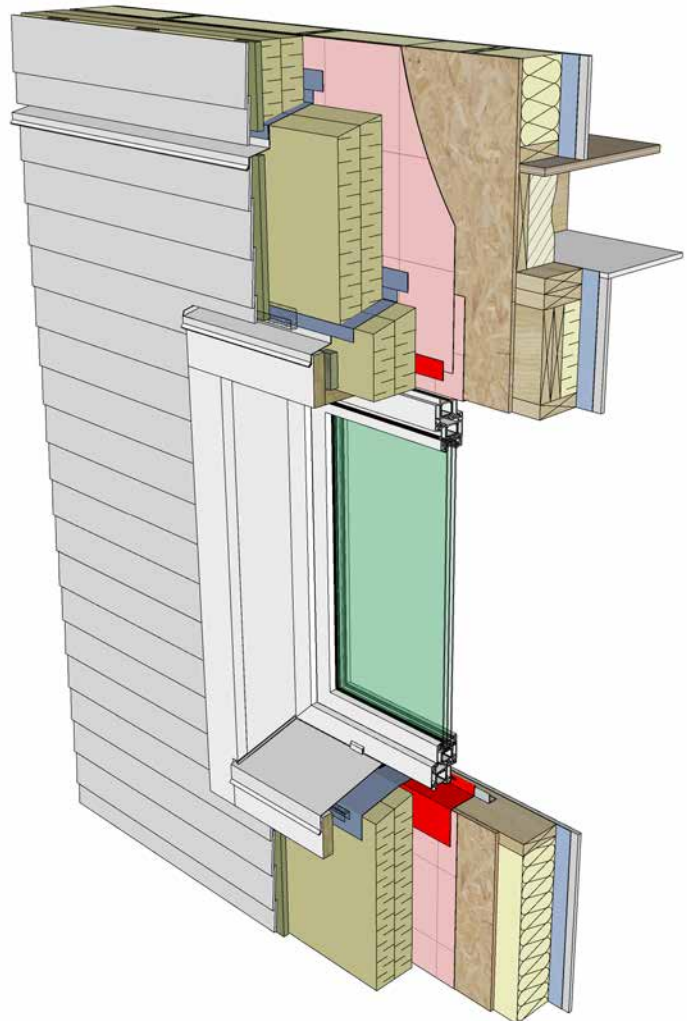

Figure 1 Split-insulated wall with exterior vapour permeable rigid insulation

## Cladding

Any type of cladding can be used with this wall assembly. The selection of the cladding attachment strategy will depend on the weight and support requirements of the cladding. In many cases, the cladding can simply be attached to vertical plywood strapping, fastened through the exterior insulation and into the backup wall. In this arrangement, the rigid exterior insulation and fasteners will act in tandem to carry the cladding load (see [Structural Requirements & Fastener Tables on page 26](#)).

Thermally efficient cladding supports and brick ties can also be used with this assembly and would permit the use of semi-rigid exterior insulation products.

## Water-Resistive Barrier

A vapour permeable sheathing membrane should be installed on the exterior of the wall sheathing, behind the exterior insulation. There are a variety of both loose (i.e., mechanically fastened) and self-adhered sheet products, as well as some liquid-applied products that can be used in this application. The sheathing membrane should be vapour permeable so as to facilitate some outward drying of the assembly.

## Air Barrier

This assembly can accommodate several air barrier strategies. However, often the most straightforward is the sealed exterior sheathing membrane. If the sheathing membrane is to form the air barrier, it must be taped and sealed to ensure continuity. Structural support of the sheathing membrane is provided by the exterior insulation and the sheathing on either side. See [Wall Air Barrier Systems on page 28](#) for further air barrier options.

### Wall Assembly #1

(dimensions as shown):

*Exterior*

Cladding (3/8")

Strapping + rainscreen cavity (3/4")

Exterior rigid insulation (6")

Sheathing membrane (Air Barrier)

Exterior sheathing (3/4")

Stud framing (5-1/2" 2x6)

Batt insulation

Vapour Control Layer

Finished gypsum board (1/2")

*Interior*

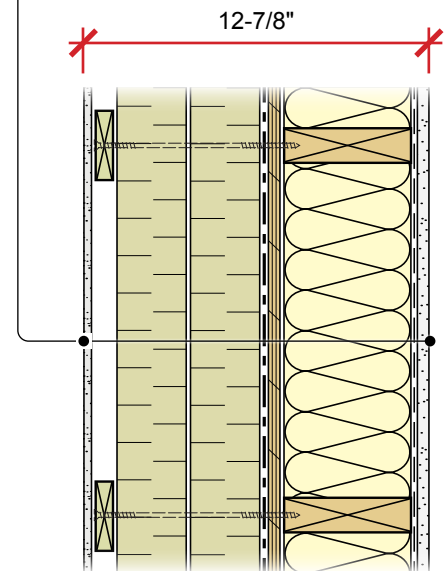

Figure 2 Typical assembly layers of the split-insulated wall with exterior vapour permeable rigid insulation

**Airtightness is a fundamental aspect of Net Zero Energy construction.** NZE homes are designed with very high levels of building airtightness (which must be tested once the building is complete), typically in the range of **1.0 ACH<sub>50</sub>** or lower regardless of the wall assembly or air barrier strategy used. Airtightness is a primary means of achieving energy performance and should be one of the builder's foremost concerns. Continuity of the air barrier at transitions and penetrations is critical to building airtightness. Increasing airtightness also reduces the potential for condensation within wall cavities thereby reducing the risk of moisture damage. See further information in Wall Air Barrier Systems on page 28 and in the Builder Checklist for Net Zero Wall Construction on page 44.

## Interior Insulation Types

The 2x6 or 2x4 stud space can be insulated using a variety of different insulation types, including batts (i.e., mineral wool or fibreglass), blown-in fibrous insulation (i.e., cellulose or fibreglass), or spray foam.

## Exterior Insulation Types & R-value

This wall assembly uses vapour permeable exterior insulation such as semi-rigid or rigid stone wool, or semi-rigid fibreglass. The permeability of the exterior insulation allows for drying to the exterior and does not present potential drying and durability challenges.

The insulation types used in this assembly have a range of R-values (measured as R-value per inch of continuous insulation), however, in general, most insulation types in this category provide approximately R-4 per inch. The following table provides a range of values for each backup wall assembly and exterior insulation thickness. Thermal bridging through the exterior insulation should be accounted for in the thermal calculations, though it is not a requirement of Part 9 of the NBC. As an example shown below, degradation due to galvanized or stainless screws varies from 5% to 10% reduction in the R-value of the exterior insulation (i.e., 90% to 95% effective).

Wall Effective R-values: Split-Insulated Wall with R-4 per inch exterior insulation attached with galvanized or stainless steel screws						
2x4 Framed Wall (R-12 Batts): <b>R-11.3*</b>			2x6 Framed Wall (R-19 Batts): <b>R-16.2*</b>			
		90% Effective (i.e., galvanized screws)	95% Effective (i.e., stainless steel screws)			
Thickness of Exterior Insulation (inches)	1.5	16.7	17	21.6	21.9	1.5
	2.0	18.5	18.9	23.4	23.8	2.0
	2.5	20.3	20.8	25.2	25.7	2.5
	3.0	22.1	22.7	27	27.6	3.0
	4.0	25.7	26.5	30.6	31.4	4.0
	5.0	29.3	30.3	34.2	35.2	5.0
	6.0	32.9	34.1	37.8	39	6.0
	7.0	36.5	37.9	41.4	42.8	7.0
	8.0	40.1	41.7	45	46.6	8.0
	9.0	43.7	45.5	48.6	50.4	9.0
	10	47.3	49.3	52.2	54.2	10
	12	54.5	56.9	59.4	61.8	12

\*A 23% framing factor is assumed which is consistent with standard 16" o.c. stud framing practices.

Figure 3 Wall #1 effective R-values table

Note: Most *Net Zero* and *Net Zero Ready* Homes labeled under the *CHBA Net Zero Home Labeling Program* have been constructed with two inches of exterior insulation or less. Fasteners for the attachment of strapping over exterior insulation, as discussed in this document, may require professional engineering approval.

## Design Considerations

In a conventional wood-framed wall assembly, cladding is attached either directly to the sheathing or over vertical strapping fastened directly to the stud wall and wood sheathing. The addition of exterior insulation increases the distance between the sheathing and the cladding. There are various approaches which can be used to support the cladding, and the selection of a method often depends on the structural loads which must be accommodated and the installation and sequencing preferences. The amount of thermal bridging associated with each of these methods varies, and is also an important consideration. In all cases, it is important that other aspects of assembly design including the provision of drainage be considered.

**Fasteners Through Insulation:** Cladding can be attached and supported by vertical strapping that is fastened with long screws through the exterior insulation and into the framed wall. This is in most cases the most thermally efficient mechanically fastened cladding support option, as thermal bridging of the exterior insulation is limited to the fasteners through the insulation. For the purposes of this guide, the term “strapping” is used to describe vertical wood furring behind the cladding. The strapping also creates a drainage space, capillary break, and ventilation cavity (i.e., rainscreen cavity) which is consistent with effective moisture-management techniques. In this arrangement, the rigid exterior insulation and fasteners will act in tandem to carry the cladding load.

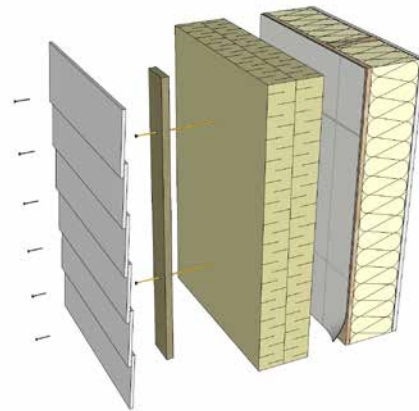

Figure 4 Fasteners through insulation

**Proprietary Thermally Efficient Spacers and Clips:** Proprietary thermally efficient spacer and clip systems can be used to facilitate installation and/or to support heavier claddings or resist larger wind loads. A number of systems exist, and selection should be made based on the thermal efficiency of the spacers in combination with the ability to support the loads and accommodate the insulation thickness. Low conductivity materials such as fiberglass and stainless steel can provide excellent thermal efficiency.

**Continuous Framing or Wood Blocks:** Cladding can also be supported using continuous wood framing which penetrates the exterior insulation, or alternatively by standard strapping installed over wood blocks (similar to [Figure 11](#)). When continuous wood framing is used, the reduction of the thermal efficiency of the exterior insulation should be accounted for, consistent with the approach for wood stud walls. Continuous framing and wood blocks can also provide the additional benefit of facilitating the use of semi-rigid insulation, rather than rigid.

**Masonry Ties:** In cases where masonry cladding is used, masonry ties are used to support the cladding in conjunction with bearing of the masonry on lintels or a shelf angle, consistent with standard practice for this cladding type. These ties can either be installed such that they penetrate the exterior insulation, or can be installed on the exterior face of thermally efficient spacer systems to reduce the thermal impact of the ties.

## Vapour Barrier and Exterior Insulation

The exterior insulation in this assembly increases the temperature of the sheathing and reduces the potential for condensation (see [Figure 5](#)). However, a vapour barrier should still be installed on the interior of the stud wall unless the majority of insulation R-value is placed on the exterior of the sheathing. Typically, a polyethylene sheet is used as the interior vapour barrier in these types of assemblies.

If a relatively low-permeance foam plastic insulation was used, it would not readily allow for moisture in the wall to dry outwards. If this insulation is installed in conjunction with an interior vapour barrier, the two vapour barriers can trap moisture that inadvertently gets into the assembly and can potentially lead to fungal growth and decay.

**In general, a vapour permeable exterior insulation in combination with an interior vapour barrier typically provides a lower risk wall assembly.**

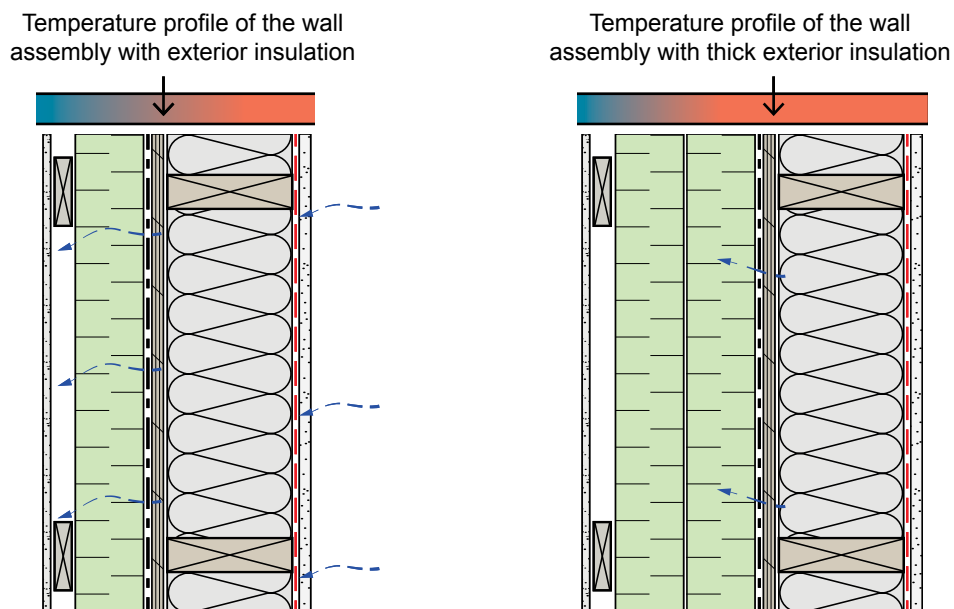

Figure 5 Exterior insulation serves to increase the temperature of the wood sheathing, which reduces the potential for condensation within the assembly. Thicker exterior insulation further minimizes this risk. Permeable exterior insulation allows any moisture that may enter the wall to dry outwards and does not trap it.

## Code Compliance and Performance Verification

The design and construction of wall assemblies used in Part 9 Housing and Small Buildings must comply with the requirements and restrictions set out in the local applicable building code, whether it is the NBC or the provincial/local versions. These include:

1. Considerations for the **materials and methods** used in the assemblies themselves, and
2. How the resulting wall thermal performance is accounted for in the **building energy performance**.

**As with all code items, responsibility for code compliance always lies with the building owner. If the owner has a legally binding Contractual Agreement with a designer or builder, then this responsibility would pass to them, as defined by the contract. The Building Official is only there to oversee and apply the local code compliance process and serve in an auditing role.**

**Materials and Methods:** Check the applicable code sections and their referenced standards to confirm how each material and installation approach must comply. Part 9 of the NBC consists of subsections for most of the "layers" of typical wood-frame wall assemblies, including the framing, the various enclosure control layers, and even interior finishes, which outline the various requirements for the materials used and how they are installed. Most materials in typical wall assemblies must comply with an applicable CSA standard. The Canadian Construction Materials Centre (CCMC) offers testing and review services to assess product compliance with building codes. However, other methods of assessing compliance and establishing "equivalency" can be used including professional engineering services. The product manufacturer will often provide the documentation relating to code compliance, but it must always be checked against the local building code. New enclosure control layer technology such as specialty membranes may come to market faster than they can be assessed, so this requires caution.

**Energy Performance:** Code requirements for effective thermal insulation are set out prescriptively in Part 9 of the NBC. Calculating wall assembly thermal performance for the purpose of demonstrating code compliance can be done with relative ease using code-defined methodology and online resources such as the [Effective R Calculator](#) from the Canada Wood Council. However, where performance-based energy code compliance is needed, the methodology is more nuanced. The various effective R-values must all be accounted for in a unique building energy model; the documentation and energy modelling must follow the code requirements, but the approach to meeting the energy performance requirements will vary across buildings (i.e., using different assemblies and energy efficiency approaches). Exactly how code compliance is demonstrated to the authority having jurisdiction (i.e., through submissions, reviews, inspections, and approvals) is up to each jurisdiction to establish and for the project team to understand and follow. Most importantly, on-site verification is becoming a bigger part of designing and building. This includes confirmation of assembly insulation R-value on site, as well as airtightness testing. Consult with your local authority having jurisdiction to confirm the performance verification and submissions requirements relating to demonstrating code compliance with performance-based code requirements.

## Exterior Insulation, Strapping & Cladding

Installation of one or multiple layers of exterior insulation with strapping and screws requires a stepped approach, as each insulation board should be attached using only the strapping as much as possible, so as to reduce the number of fastener penetrations through the insulation and sheathing membrane. This approach is most easily completed using the following installation procedure (see [Figure 6](#)):

1. Install the starter course of insulation using the strapping fastened at the bottom edge and held upright in place as needed. Insulation boards should be installed with the vertical edges offset 8" from the strapping so that each board (usually 48" wide) will be secured behind 3 separate straps.
2. Place the insulation behind the strapping and "stack" it on the starter course, with screws installed along the strapping through the insulation boards as they are installed up to the top edge.
3. Insulation boards in a single layer can be stacked directly above the course below or offset horizontally, and they should be offset in both directions if multiple insulation layers are used.

An alternative installation approach is to use one or two fasteners to temporarily pin the insulation boards in place before the strapping is installed. This approach may require screws with large washers to adequately secure heavier insulation. Refer to the insulation manufacturer's product data for further guidance on fastener layout and installation requirements.

Boards should be installed in as large as possible pieces over the wall area. Pieces can be cut after installation to ensure all wall surfaces, including around openings and penetrations, are covered while minimizing gaps and insulation board joints. Exterior insulation should only be interrupted by necessary flashing, service penetrations and structural elements.

### Rainscreen Free Area

Some jurisdictions require a rainscreen with a minimum free area of 80%, meaning that material used to create the space must not exceed 20% of the cross-sectional area of the drained and vented cavity. This requirement can generally be met with most strapping arrangements, including the strapping widths given in the tables in the following section. However, at details or terminations wherever additional insulation or cladding support is necessary, narrower strapping or intermittent pieces should be used as infill for wall assemblies where 3" wide strapping is used, in order to maintain the 80% free area. Builders and designers should confirm that the drained vented cavity is acceptable to the authorities having jurisdiction.

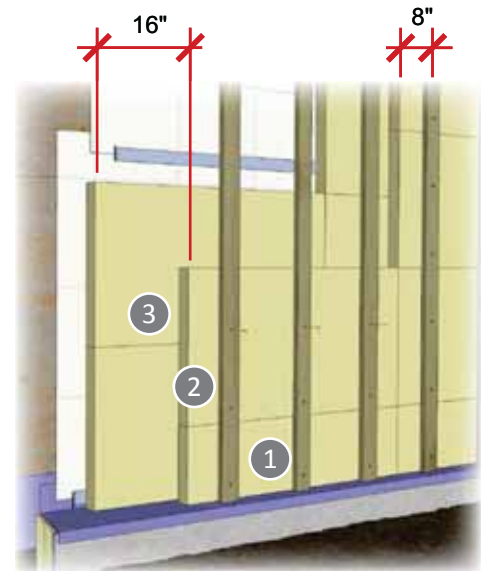

Figure 6 Exterior insulation installation method

## Rainscreen/Insulation Retention Strapping

In general, the most appropriate strapping for this application will be preservative-treated plywood strapping ripped to width, since the requirements for larger screws at close spacing risk splitting strapping made from dimension lumber. Additionally, after the strapping is installed, more fasteners are installed into the strapping to secure the cladding. Borate preservative treatments are often suitable for wood strapping, and are recommended for most applications. Alkaline copper quat (ACQ) and chromated copper arsenate (CCA) may also be suitable wood treatments, though compatibility with fasteners and adjacent metals should be checked.

The required strapping thickness and width for structural purposes are a function of the cladding weight. Thicker and wider strapping may be necessary when used with rigid mineral wool products in order to reduce potential bowing or twisting of the strapping between fasteners as it is installed and as cladding is attached.

Strapping thickness and width should meet the minimum requirements given in the tables in the [Structural Requirements & Fastener Tables on page 26](#), though they are not constrained to the sizes given and can be wider and thicker where appropriate. For example, some cladding products may require a minimum fastener embedment that is thicker than the minimum strapping thickness given in the tables, as specified by the cladding manufacturers. Additionally, refer to the code requirements for minimum strapping dimensions and spacing in Part 9 construction.

## Optimizing Strapping Layout

The strapping layer in exterior-insulated assemblies must efficiently retain the exterior insulation. In unobstructed “clear-field” wall areas, strapping installation may be relatively straightforward (see previous page). However, the strapping must still accommodate the openings, penetrations, cladding joints, attachment of flashings and trims, and separations at floor lines. Optimize strapping layout by:

- › Carefully planning the layout to avoid extra strapping pieces, especially around windows and penetrations,
- › Reducing the number of insulation pieces by using the largest possible piece since each one needs to be held in place at each side/end,
- › Simplifying the trim and flashing arrangement to reduce the need for small insulation blocks, and
- › Using intermittent blocking receive closure/return trim and flashing running across the thickness of the exterior insulation (see [Figure 7](#) and [Typical Construction Details starting on page 32](#)).

When considering the number of penetrations and estimating the amount of screws needed, remember that while structural requirements can allow large vertical screw spacing along the strapping (see [Structural Requirements & Fastener Tables on page 26](#)), this spacing is only available at clear-field wall areas. At windows and doors, strapping pieces must be placed at the outside perimeter, with fasteners at the ends of the straps regardless of how short they are. The same is true for wall areas with joints and flashing at floor lines. The strapping should always be properly attached with at least fasteners at each end.



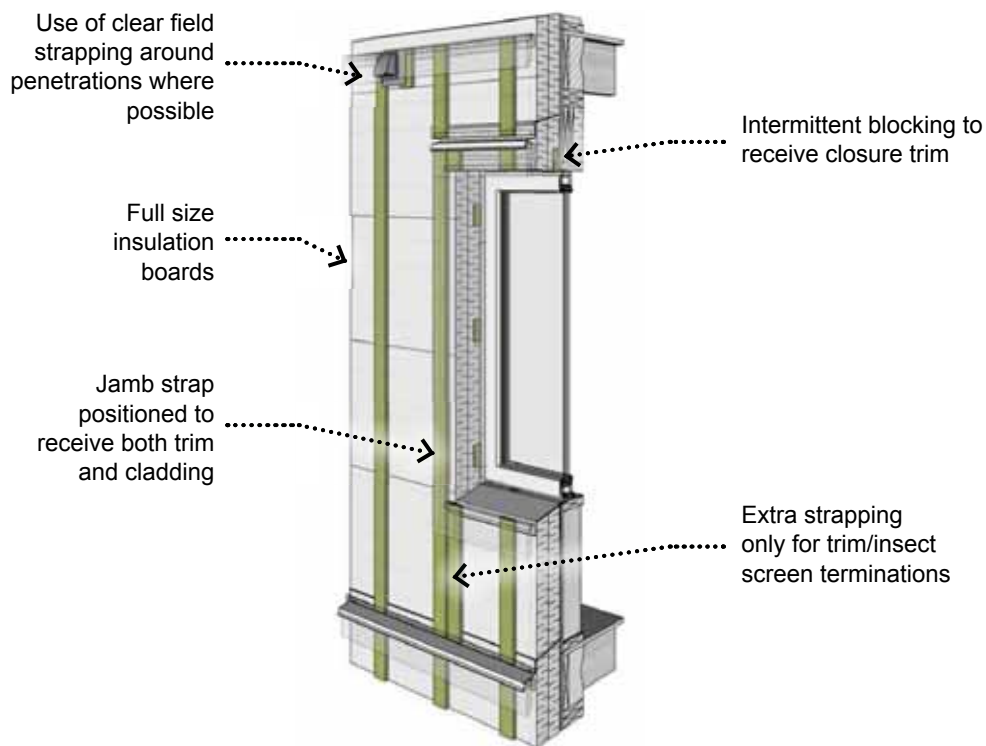

Figure 7 Examples of optimized strapping layout

## Rainscreen Details

The depth of the insulation retention strapping also serves as the rainscreen space between the cladding and the face of the exterior insulation. While it is not used as the primary water-resistive barrier (WRB) acting to stop water penetration into the wall assembly, the exterior insulation acts as a secondary water-shedding surface (WSS). Cladding transitions and joints should be detailed to permit drainage from behind the cladding. In some key locations, like above penetrations and cladding transitions, the detailing must also allow drainage from behind the insulation at the WRB (i.e., be a through-wall flashing). This is best achieved with the combination of metal flashing at the face of the insulation and a self-adhered membrane between the WRB and the back leg of the flashing. The back leg of the flashing can be attached either with fasteners directly through the insulation, or onto intermittent preservative-treated wood-blocking. By not having the flashing carry through the insulation and instead using a self-adhered membrane, potential thermal bridging is minimized and more typical flashing profiles can be used (see next page). Note that while a continuous metal through-wall flashing could be used, it would require custom profiling and would be considered a significant thermal bridge.

Insect mesh, also referred to as bug screen, should be used at all flashing joints where the rainscreen/strapping space is exposed and could allow insect entry. The bug screen is temporarily retained between the strapping and the insulation, wrapped over the ends of the strapping, and fastened to its front face. See the schematic details on the following page and refer to the [Typical Construction Details starting on page 32](#) for further guidance.

The conventional through-wall flashing approach is to positively lap the field membrane onto the flashing or flashing membrane and tape/adhere it in place to maintain airtightness (see [Figure 8](#)). This approach requires careful planning so that the flashing is placed at the correct height to allow both the lapping and sealing with the field membrane as well as the installation of the metal flashing and trim.

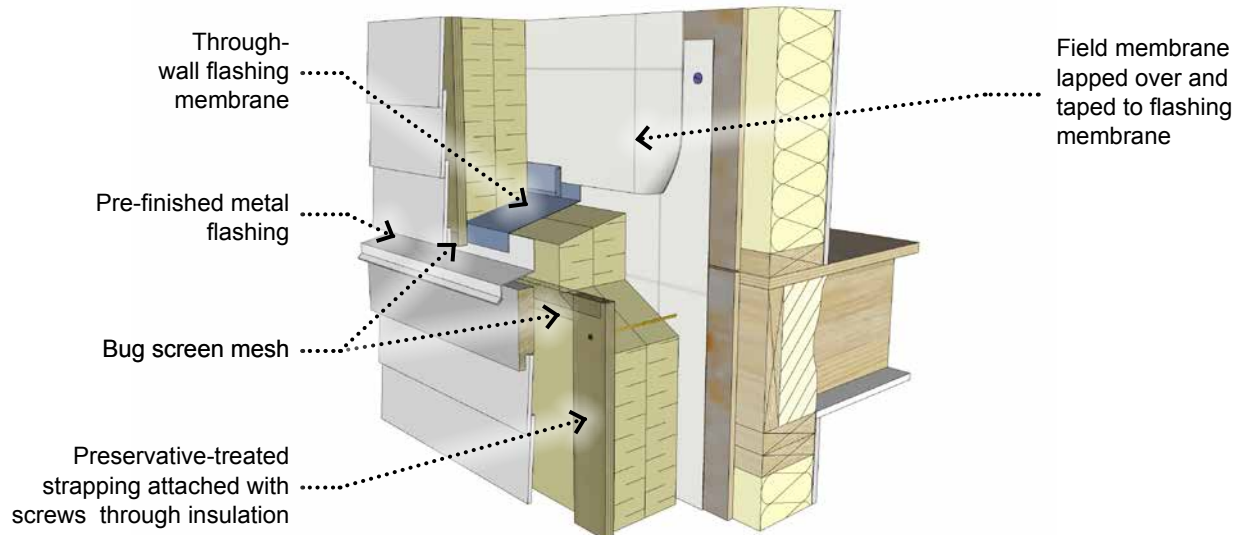

Figure 8 Conventional through-wall flashing detail and strapping installation

As a second option, it may be simpler to install the flashing membrane over top of the field membrane with the top edge taped or sealed, rather than having a positive lap (see [Figure 9](#)). **Note however that specific code requirements for flashings may dictate how flashings are installed, and the conventional positive lapping is often required.**

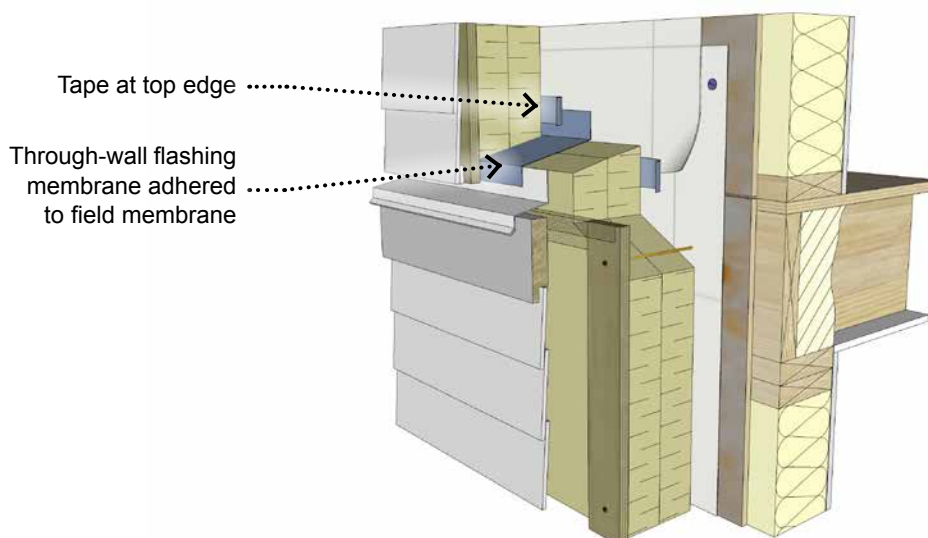

Figure 9 Simplified through-wall flashing approach (without positive laps)

## Through-Wall Metal Flashing Attachment

The flashing installation approach requires some changes to the typical sequencing of the cladding installation. Where the wall field membrane was previously installed together with the metal flashing before the bug screen and strapping, the addition of exterior insulation means that the metal flashing is instead installed with the insulation and strapping.

The modified flashing installation consists of the following steps (see [Figure 10](#) on the next page):

1. The exterior insulation must be carefully installed to account for the through-wall flashing. As shown in [Figure 10](#), the top edge of the "lower" exterior insulation aligns with the top of the back leg of the flashing, and acts as the sloped substrate for the flashing membrane (note that the "upper" insulation is not installed until the flashing is in place).
2. The flashing is then installed with fasteners through the back leg of the flashing, through the insulation, and into the wall substrate. These few fasteners are not intended as structural attachment, but are simply used to position the flashing and hold it in place against the insulation until the upper insulation and strapping is installed and can be used to fully secure it. The flashing back leg should be pre-drilled for easier fastener installation and so that regular wood screws can be used since self-tapping screws may needlessly damage the wall membrane.
3. With the metal flashing in place, the flashing membrane can be lapped over and adhered to its back leg. Aligning the deep through-wall flashing membrane above the intended future trim/flashing locations during the field membrane installation may be difficult. Instead, the through-wall membrane may be best installed during the metal flashing installation, as shown in [Figure 10](#). The flashing membrane could still be installed during the field membrane installation as long as it includes enough extra width and the release paper is left in place to allow the metal flashing to be installed later in the correct position. While the flashing membrane likely will not adhere to the insulation, it will be sandwiched in place by the upper insulation, and serves its purpose as the through-wall drainage. Note that specific code requirements for flashings may dictate how flashings are installed. Consult with your local authority having jurisdiction to confirm what flashing approaches may be acceptable.
4. The upper insulation and strapping are then installed over the flashing (with bug screen behind the strapping), and small fasteners can be used to fully secure the back leg of the metal flashing.

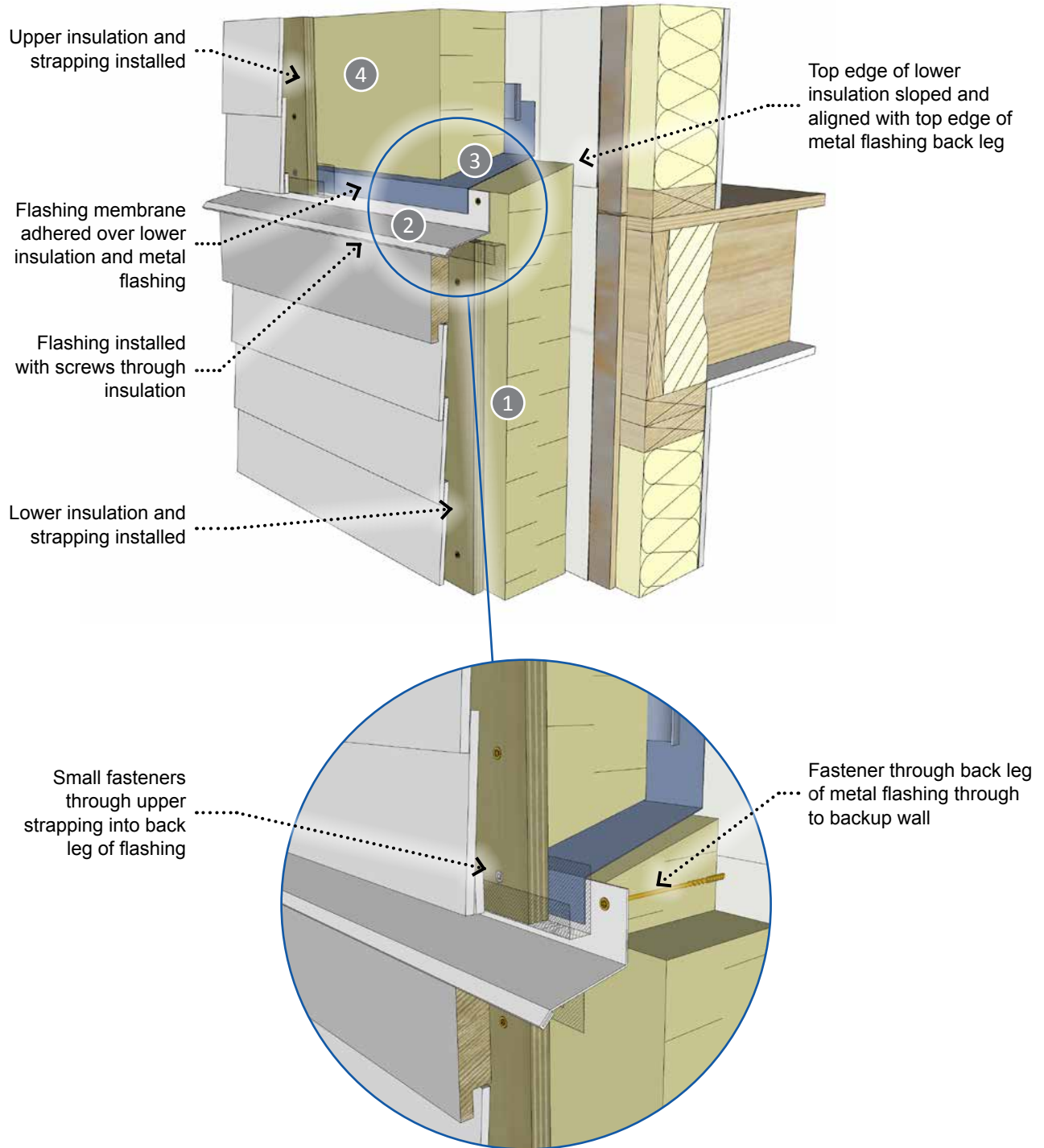

Figure 10 Through-wall flashing installation: metal flashing installed with screws at the front face of the exterior insulation, flashing membrane installed over lower insulation and adhered to metal flashing, and upper strapping used to secure flashing in place.

## Fasteners and Corrosion Protection

Screws used to attach the strapping over the insulation should be either stainless steel or steel with a high-quality corrosion protection coating as they will be exposed to the exterior environment and should be protected from corrosion to ensure long-term durability. Additional resistance may be required in highly corrosive environments. Always ensure the screw type is compatible with both the strapping material (i.e., the wood preservative treatment) and the cladding material.

This application may require specialty screws designed to accommodate the potentially large torque expected as they are installed through thick layers of insulation and into the backup wall. One important construction consideration is the use of screws with a countersunk head so that the screw head can be embedded into the front face of the strapping and out of the way of cladding materials and attachment accessories.

## Cladding Weight and Attachment Methods

Testing has shown that some minor deflection of the strapping and cladding may be experienced for wall assemblies with heavy-weight claddings. In most cases, the deflection is constrained to less than 1/32" for typical heavy-weight cladding loads. Potential deflection for heavy-weight cladding may be reduced by using deflection blocks at the top of the strapping pieces, or by installing screws at an upwards angle into the backup wall. The approach with deflection blocks uses pressure-treated dimension lumber blocking, installed at the top of the strapping either at the rim joist or at the top of the wall, in order to "hang" the strapping (see illustration on the following page). This provides a solid wood support mechanism and minimizes the deflection movement of the cladding.

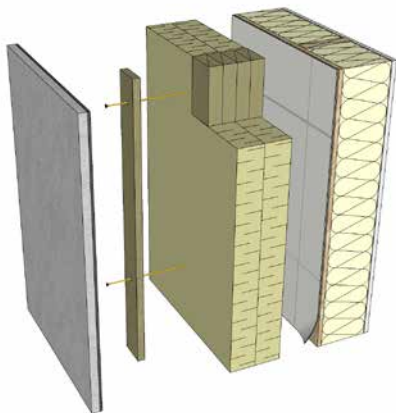

Figure 11 Preservative-treated deflection blocks installed at the top edge of the flashing can be used to limit deflection and support heavier-weight claddings if needed.

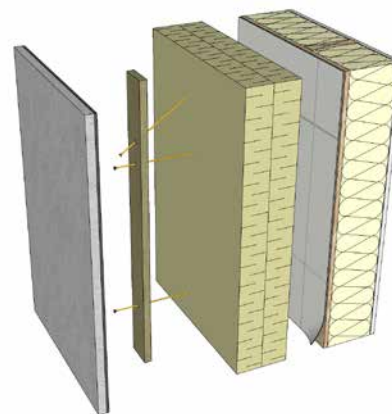

Figure 12 Screws installed at an upward angle can be used to limit deflection and support heavier-weight claddings if needed.

At outside corners, wider vertical strapping sized to extend out beyond the corner framing can be used to achieve a continuous cladding attachment substrate (see [Figure 13](#)). For vertically-oriented cladding, two layers of strapping should be used, or if the cladding is lightweight and there is no requirement for a rainscreen cavity, horizontal strapping could be installed alone (see [Figure 14](#) and [Figure 15](#)).

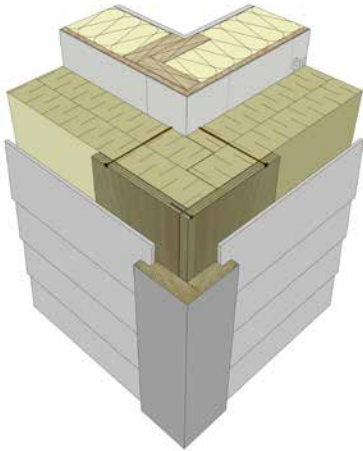

Figure 13 Wider corner strapping installation where corner trim must be installed onto strapping.

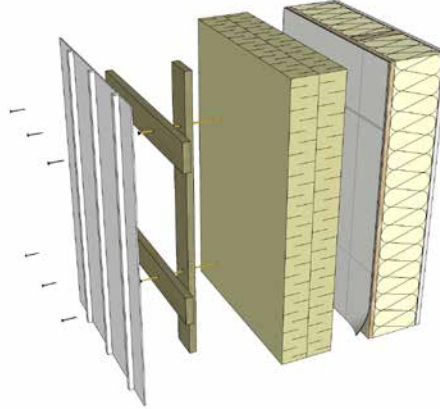

Figure 14 Cross-strapping is used to produce a horizontal strapping substrate for vertical cladding.

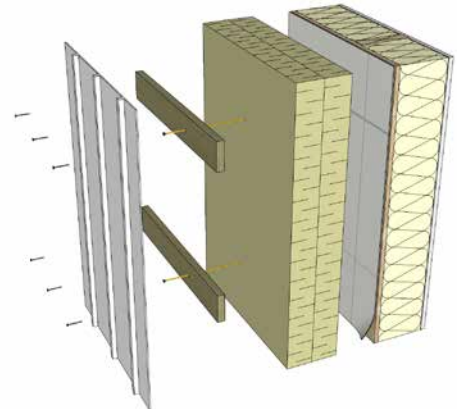

Figure 15 In dry climates with no rainscreen requirements, horizontal strapping alone can be used.

## Window Installation

The exterior insulation presents some unique sequencing challenges for window and door installations.

### The window and door detailing must:

- › Allow for timely rough opening preparation and window installation in order to reach lockup stage,
- › Accommodate both flange and non-flange windows
- › Anticipate the future flashing, insulation, strapping, and cladding components, and
- › Maintain robust air sealing and water management strategies.

[Figure 16](#) shows three examples of the primary window sill membrane material and installation method in order to achieve a continuous air and water seal across the sill, at the sill corners, and at the sill angle. The typical window membrane prestrip arrangement at the head, as shown in [Flashing Above Openings on page 25](#), will accommodate the new detailing approach with exterior insulation. However, additional window sill membrane detailing may be needed so that water can drain out from beneath the window across the potentially thick exterior insulation to the rainscreen cavity or the exterior. There are three basic sill drainage detailing options for the window sill as shown in [Figure 18](#).

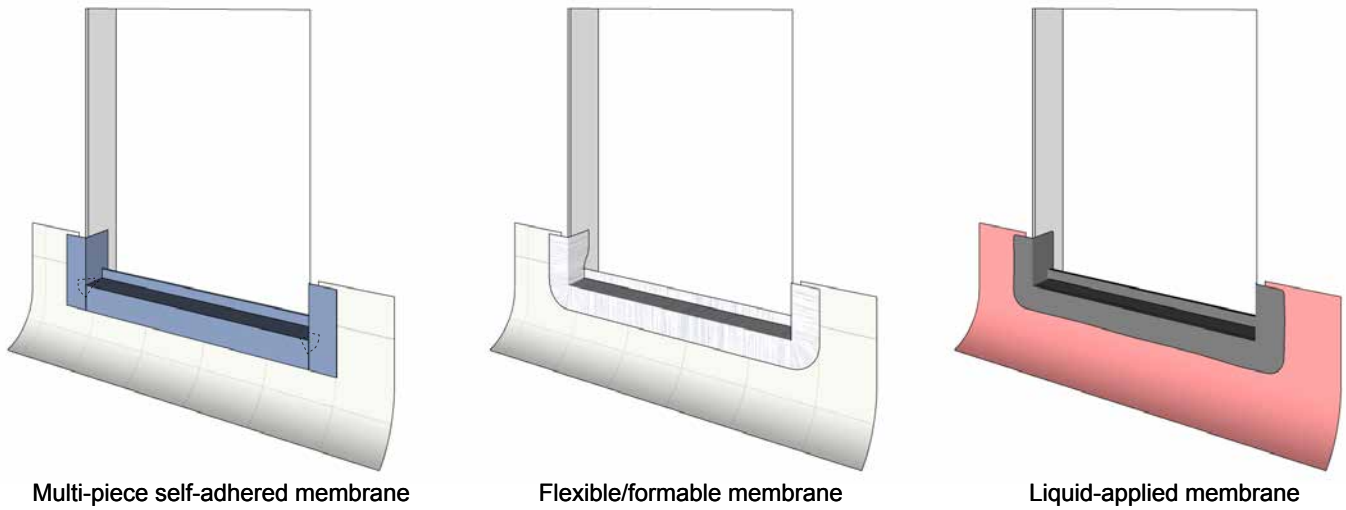

Figure 16 Examples of window sill membrane installation at the rough opening

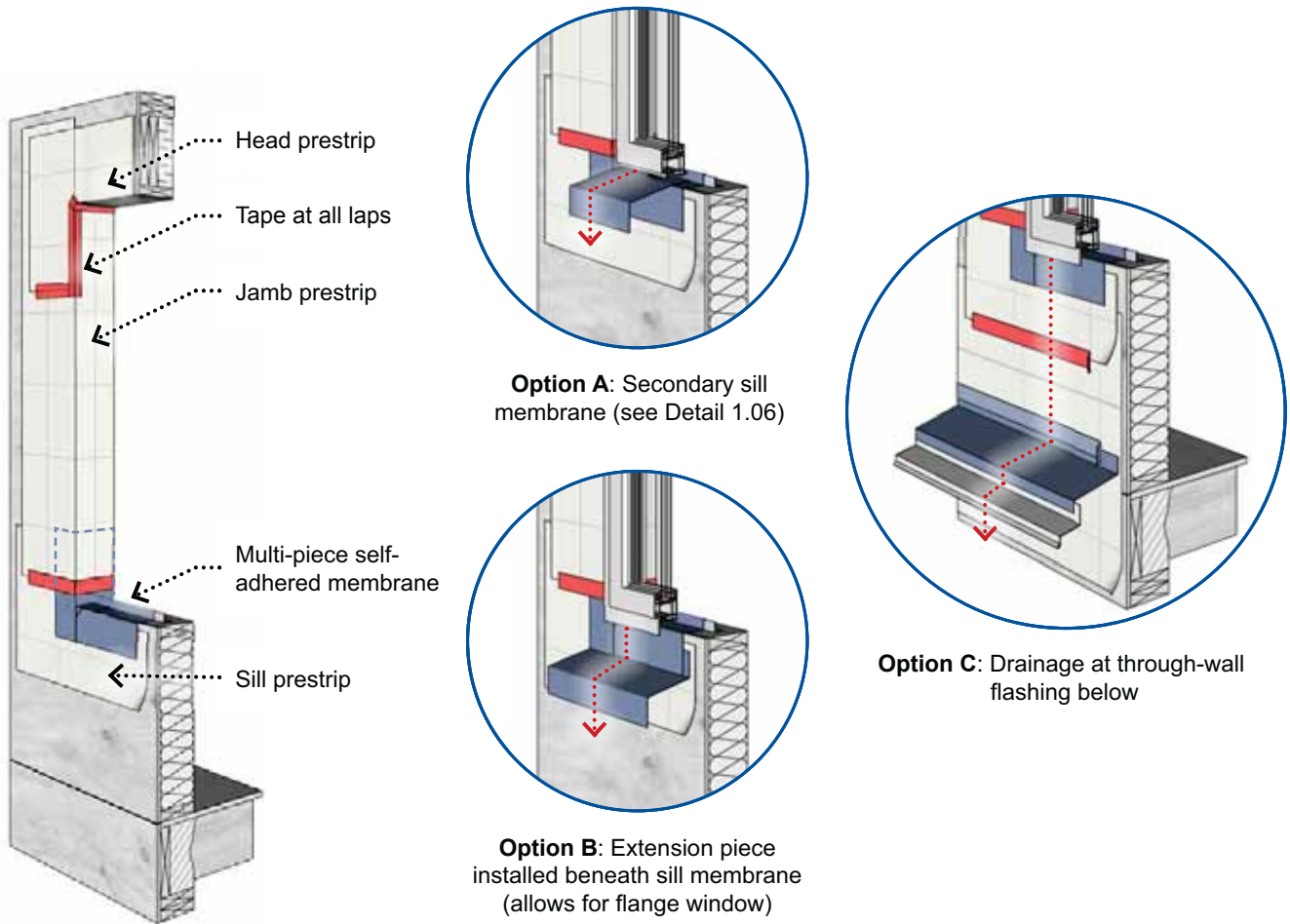

Figure 17 Window rough opening membrane installation at the sill, jamb and head.

Figure 18 Sill drainage options (exterior insulation and cladding not shown for clarity)

## Flange and Non-Flange Windows: Perimeter Seal and Attachment

**Seals:** The baseline approach for sealing between the window frame and the rough opening at the sill is to use a metal angle or wood block, with the sill membrane wrapped over it so that the back of the window frame can be set into a sealant bead (see [Figure 19](#)). The sill angle provides increased moisture penetration resistance as it provides a back dam and elevates the location of the sealant used for the air and water seal above the surface of the sill membrane and away from potential moisture sources. Backer rod and a sealant bead are used at the jamb and head.

Note that per the code-referenced Canadian standard *CSA A440.4-19: Window, Door, and Skylight Installation*, if a sill angle or block is not used, then the sill membrane must be sloped to the exterior. In this case the interior seal at the sill would typically be backer rod and sealant. The baseline sill detailing approach shown throughout this guide series is a metal sill angle.

For any window detailing approach, the air and water seal should transfer between the window and the rough opening membrane at the **interior plane of the frame**, with drainage to the outside provided at the sill membrane. The same sealing approach is used for both flanged and non-flange windows. Sheathing tape at the outside perimeter of the flange is optional at the jamb and head for extra water-shedding protection, but a drainage path must always be maintained past the window sill flange through the use of shims or furring (see [Figure 19](#)).

**Attachment:** Windows can be attached from the interior using clips and the sill angle, or at the exterior with fasteners through the flange. Per *CSA A440.4-19*, the sill membrane must not have penetrations through its horizontal drainage surface.

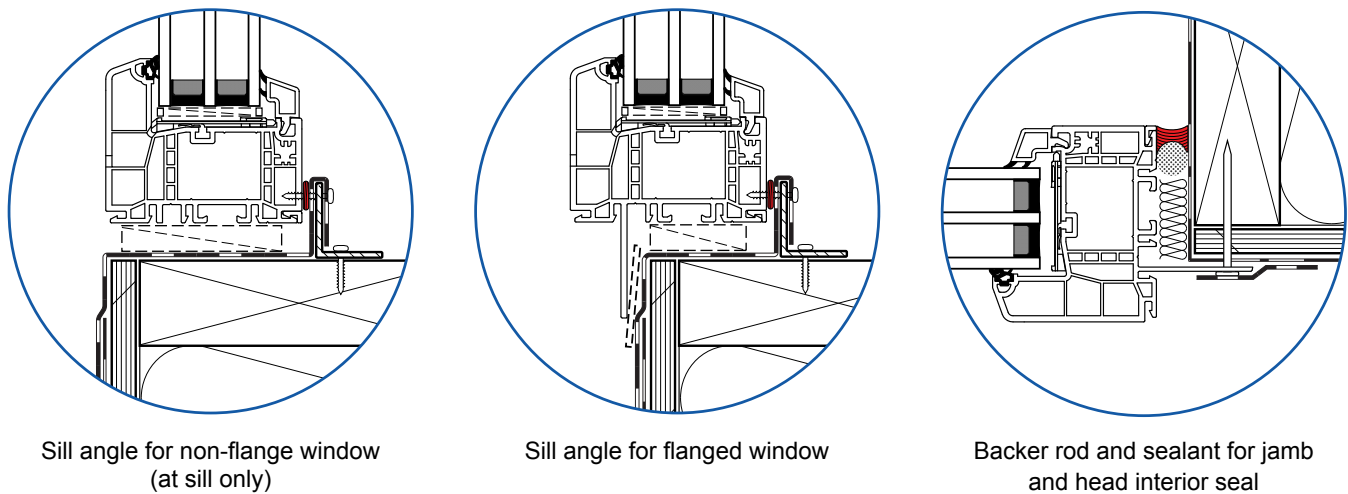

Figure 19 Window rough opening air and water sealing options

Window details provided in [Typical Construction Details starting on page 32](#) are based on best practice for this wall assembly. Refer also to the Canadian Standard *CSA A440.4-19: Window, Door, and Skylight Installation* for code requirements, including sealing and flashing, in Part 9 buildings.



## Flashing Above Openings

While *CSA A440.4-19* should be considered in all window detailing, the use of exterior insulation means that the amount of moisture that may actually reach the WRB is relatively low. The exterior face of the exterior insulation can be considered as a secondary water-shedding surface, so most of the water that may reach past the cladding is likely shed from there. Therefore, this assembly may allow for some relaxations in the number of through-wall flashings needed, especially above openings like windows. Instead of running flashing membrane through the insulation and back to the WRB (see [Figure 20](#) and [Figure 21](#)), the metal flashing could simply be installed at the face of the insulation or even the face of the strapping behind the cladding, with no flashing membrane. If needed, a secondary head flashing could be installed so that it terminates beneath the head return trim/flashing. See [Figure 22](#) and [Figure 23](#) below. This approach simplifies the overall detailing approach at the window head.

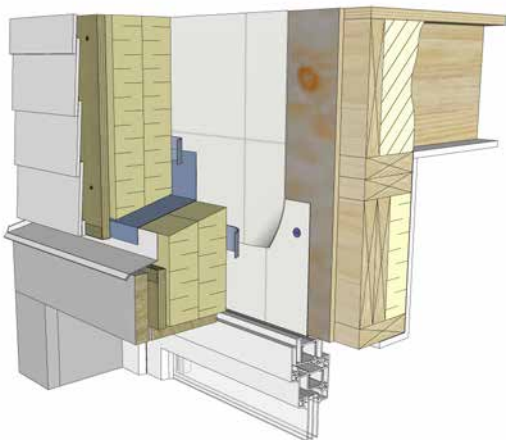

Figure 20 Window head flashing with taped through-wall flashing membrane.



Figure 21 Window head flashing with through-wall flashing membrane lapped beneath the field membrane.

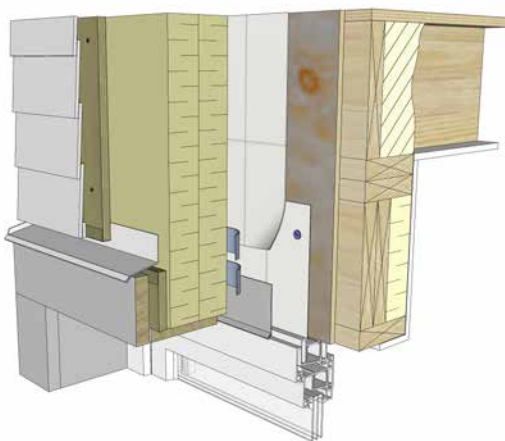

Figure 22 Window head flashing installed at the front face of the exterior insulation with secondary flashing installed directly above window.

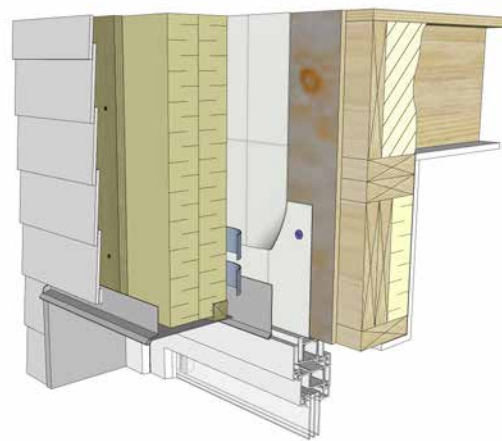

Figure 23 Window head flashing installed at the front face of the strapping with secondary flashing installed directly above window.

## Structural Requirements & Fastener Tables

The following information provides the structural requirements for attaching strapping over exterior insulation using screws. The tables are organized by cladding weight, with fastener requirements shown for insulation thicknesses up to 8". Illustrations of each aspect of the fastener and strapping installation requirements are shown below.

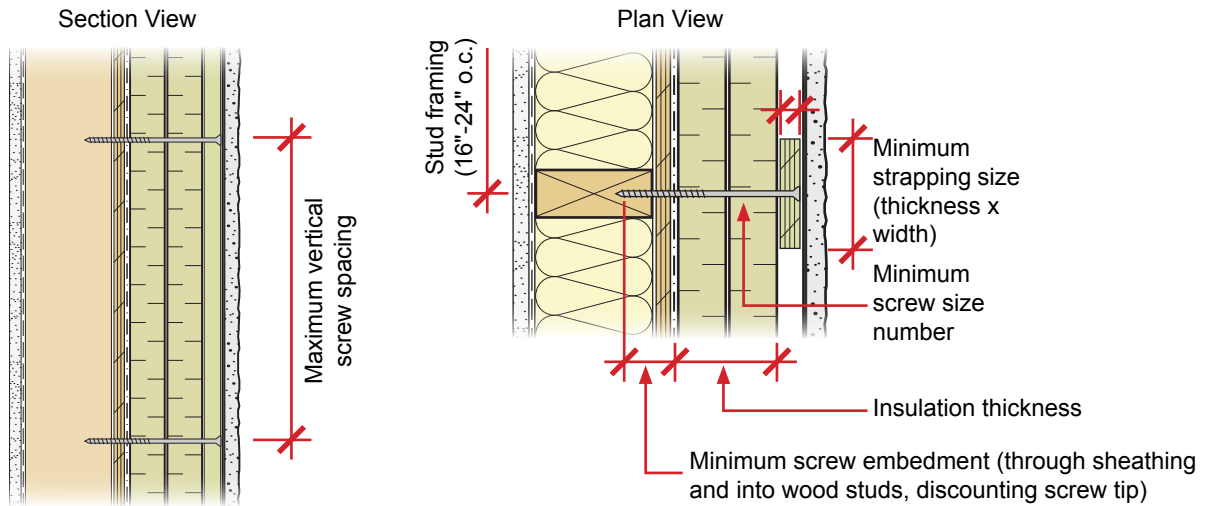
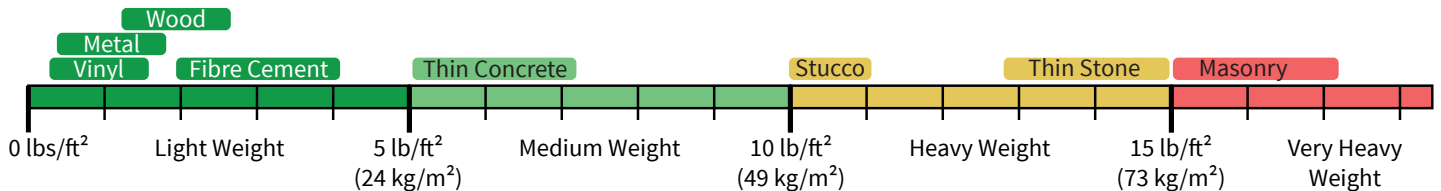

Figure 24 Design aspects of the strapping and fastener installation

### Cladding Weight

Cladding weights for the purpose of the structural calculations included in this guide are categorized as **Light** (less than 5 lbs/ft<sup>2</sup>, 24kg/m<sup>2</sup>), **Medium** (5 to less than 10 lbs/ft<sup>2</sup>, 24–49 kg/m<sup>2</sup>), **Heavy** (10–15 lbs/ft<sup>2</sup>, 49–73 kg/m<sup>2</sup>), and **Very Heavy** (over 15 lbs/ft<sup>2</sup>, 73 kg/m<sup>2</sup>) weight cladding. The approximate weight and category for various common cladding types are shown below. Each cladding type will have different weights for different brands and cladding arrangements, so the specific cladding weight should be determined from product technical data to confirm which category it is in.



### Thicker Plywood Sheathing

Note that 3/4" plywood sheathing can likely serve as the sole fastening substrate in place of thinner plywood or OSB sheathing and studs. Using thicker plywood sheathing can help simplify the strapping installation, since it avoids having to align the screws with the studs. Exterior rigid insulation manufacturers often provide detailed guidance on insulation and cladding attachment methodologies.

## Fastener Tables\*

Assumed Structural Properties	
Rigid mineral wool minimum compressive strength	Stainless /galvanized steel screw allowable tensile strength
439 psf (21 kPa) @ 10% compression, ASTM C165 testing	60,000 psi (414 MPa)

Example Screw Fastener Products	
Trufast HD Roofing Fasteners	GRK Fasteners R4, RSS, RT
My-Ti-Con ASSY Eco	Heco-Topix
Simpson StrongDrive SDWS Timber Screw	SFS Intec Dekfast

### Light Weight Cladding

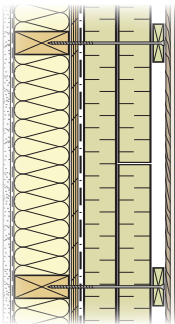

Fastener/Strapping Installation Requirements - Light Weight Cladding				
Thickness of Exterior Insulation	Maximum Vertical Screw Spacing	Minimum Screw Size	Minimum Screw Embedment	Minimum Strapping Size
Light Weight Cladding Below 5 lbs/ft <sup>2</sup> - 16" o.c. Stud Framing				
1" to 2"	24"	#10	1-1/2"	3/4" x 2-1/2"
>2 to 8"	16"			
Light Weight Cladding Below 5 lbs/ft <sup>2</sup> - 24" o.c. Stud Framing				
1" to 2" *	16"	#10	1-1/2"	3/4" x 3"
>2" to 8"	12"			

### Medium Weight Cladding

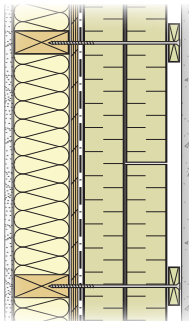

Fastener/Strapping Installation Requirements - Medium Weight Cladding				
Thickness of Exterior Insulation	Maximum Vertical Screw Spacing	Minimum Screw Size	Minimum Screw Embedment	Minimum Strapping Size
Medium Weight Cladding Between 5 lbs/ft <sup>2</sup> and 10 lbs/ft <sup>2</sup> - 16" o.c. Stud Framing				
1" to 4"	16"	#12	1-1/2"	3/4" x 3"
>4" to 8"	12"			
Medium Weight Cladding Between 5 lbs/ft <sup>2</sup> and 10 lbs/ft <sup>2</sup> - 24" o.c. Stud Framing				
1" to 4"	12"	#12	1-1/2"	3/4" x 3"
>4" to 8"	8"			

### Heavy Weight Cladding

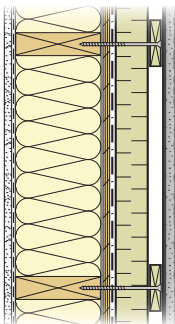

Fastener/Strapping Installation Requirements - Heavy Weight Cladding				
Thickness of Exterior Insulation	Maximum Vertical Screw Spacing	Minimum Screw Size	Minimum Screw Embedment	Minimum Strapping Size
Heavy Weight Cladding Between 10 lbs/ft <sup>2</sup> and 15 lbs/ft <sup>2</sup> - 16" o.c. Stud Framing				
1" to 2"	16"	#14	1-1/2"	3/4" x 3"
>2" to 8"	12"			
Heavy Weight Cladding Between 10 lbs/ft <sup>2</sup> and 15 lbs/ft <sup>2</sup> - 24" o.c. Stud Framing				
1" to 2"	16"	#14	1-1/2"	3/4" x 3"
>2" to 4"	12"			
>4" to 8"	8"			

\*The values provided in the above tables pertain only to wood-frame wall assemblies on low-rise buildings less than three storeys.

## Wall Air Barrier Systems

The wall air barrier system is one of the most important control layers in the assembly. Exterior air barrier approaches generally offer the simplest installation and detailing steps.

### Mechanically Attached Sheathing Membrane

Mechanically fastened systems use an airtight sheathing membrane, also referred to as house wrap, attached to the exterior sheathing with fasteners and washers. **Joints, penetrations, and laps are made airtight using sealant, tape, and self-adhered sheathing membrane strips.**

Care should be taken to ensure the sheathing membrane is adequately attached to the building during construction and it should be supported by strapping or cladding to avoid damage.

This air barrier approach is the primary air barrier approach shown in the [Typical Construction Details starting on page 32](#).

Note that the sheathing membrane is also usually used as the water-resistive barrier, and must be installed and detailed as such.

### Vapour Permeable Self-Adhered Membrane

Self-adhered sheathing membranes rely on the adhesion to the substrate as well as the adhesion at membrane laps. The membrane should be installed so that it is fully adhered to the substrate upon initial installation. The membrane should also be installed onto a suitable dry substrate that provides continuous backing.

It is important that a vapour permeable membrane product is used to avoid potentially trapping moisture within the wall cavity. Materials with a vapour permeance greater than  $60 \text{ ng/s} \cdot \text{m}^2 \cdot \text{Pa}$  are considered vapour permeable per Section 9.25. in the NBC (and provincial/local versions), though the

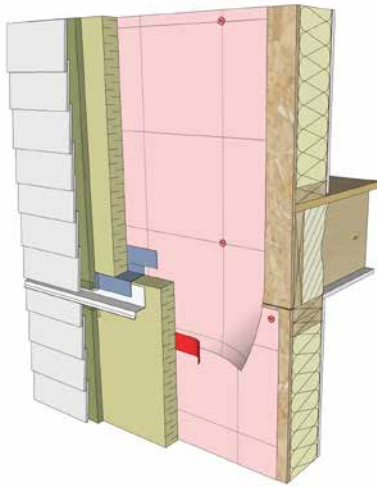

Figure 25 Mechanically fastened sealed sheathing membrane, with all edges of the airtight material taped.

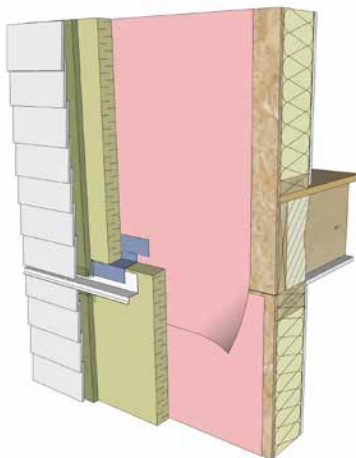

Figure 26 Vapour permeable self-adhered sheathing membrane, with all edges fully adhered to itself and the substrate to create an airtight layer.

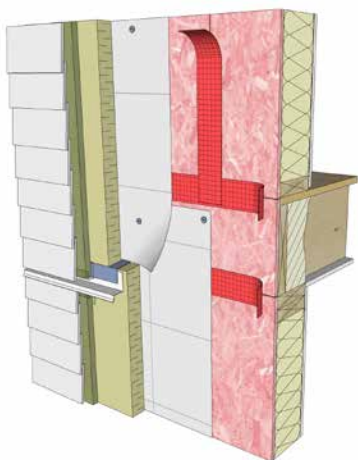

Figure 27 Sealed exterior sheathing air barrier approach

higher the permeance the better.

### Sealed Exterior Sheathing Approach

The exterior sheathing, when sealed at joints and interfaces, can also act as the primary air barrier element. This approach uses the exterior sheathing together with either sealant, liquid applied sheathing membrane, strips of membrane, or sheathing tape to create a continuous air barrier at the sheathing joints. Note that high-performance tape that can adhere well to the wood sheathing is used, not the typical sheathing tapes used with synthetic membranes or interior polyethylene.

A sheathing membrane is often required with this approach to provide the water-resistive barrier, unless proprietary water-proof sheathing and appropriate detailing is used.

### Liquid Applied Membrane

While less common, exterior liquid applied membranes share many of the advantages of self-adhered membranes and are especially useful for complex detailing. Liquid applied membranes rely upon a supporting substrate to provide a continuous backing in order to achieve an airtight barrier. Joints typically require specific detailing considerations and often incorporate membrane reinforcement. These systems are generally purchased as complete proprietary systems, including surface preparation material and primer, detailing products, and reinforcing mesh. The field membrane is installed either as roll-applied or spray-applied products. Note that the substrate and weather conditions can have a significant impact on curing time and adhesion. The manufacturer's instructions should be strictly followed.

Liquid applied membranes are generally used as the water resistive barrier, and must be detailed and installed as such.

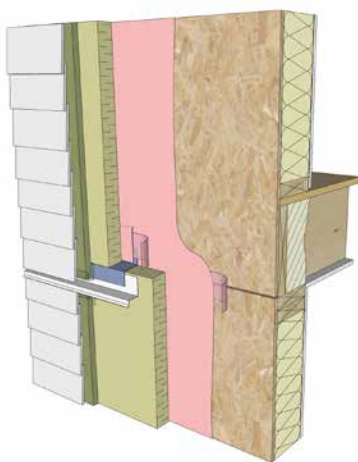

Figure 28 Liquid applied air barrier membrane

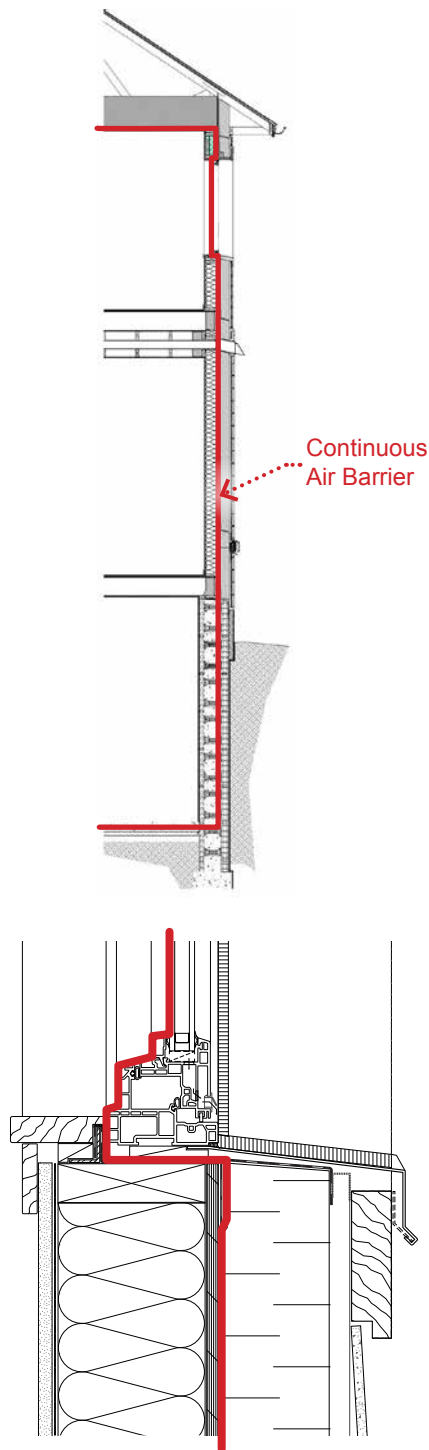

Figure 29 Example air barrier lines of continuity across the entire building enclosure and including all transition details.

## Air Barrier Detailing

The most important aspect of designing an airtight enclosure is detailing the interfaces and penetrations, because this is where discontinuities are most likely to occur. While the individual air barrier materials and components provide control of air movement for each individual assembly, how and where each assembly intersects and the continuity of the air barrier across these joints should be the focus of the detailing work. Whether at the base of wall, windows, service penetrations, roof-to-wall interface, or countless other detail locations, the details should provide a clear indication of the air barrier continuity across the building enclosure.

A best practice design technique for ensuring continuity of the air barrier is to draw a continuous line around the enclosed space. This can help to identify the air barrier on building plans, sections, and details. The line should continue around the entire enclosure and connect back to itself with no discontinuities. It should be possible to trace the air barrier without, as it were, lifting one's pen off the paper. The same concept applies to individual detail drawings as well. A detail should be prepared for all air barrier interface locations, clearly showing how continuity is maintained. Reviewing these transitions early on and collaborating with the affected trades will allow locations with constructability or sequencing issues to be identified and help determine if a revised detail is necessary.

Assemblies with interior air barriers in particular must account for all the potential interruptions and interfaces at the interior face of the building. Details for these locations should include all necessary components and products, and basic installation measures, to provide a continuous air barrier across all elements of the assembly. See [Typical Construction Details starting on page 32](#).

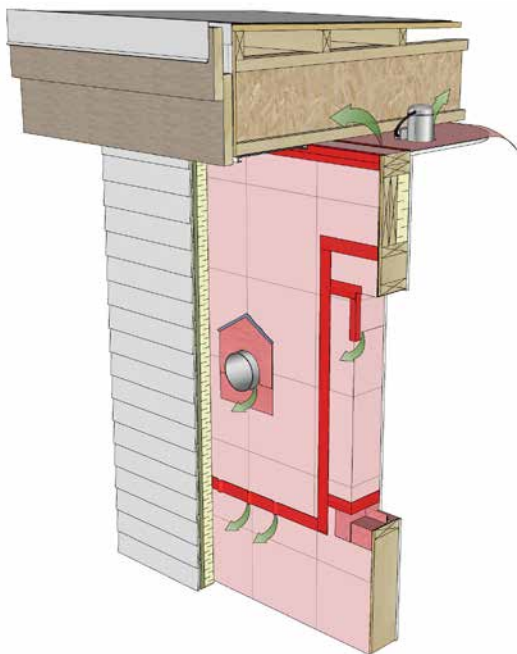

Figure 30 Common sheathing membrane and ceiling air barrier deficiencies.



Figure 31 Example airtightness sign to use on site for notifying all staff and trades.

## Common Air Barrier Deficiencies & Challenges

Common deficiencies and challenging areas for exterior air barrier installation can occur at all areas of the air barrier system. The integrity of the air barrier relies upon the quality and completeness of the installation work. Some common air barrier deficiencies and likely deficiency locations include:

- › Structural and service penetrations using sealant and membranes
- › Wrinkled, fishmouth, incomplete membrane laps
- › Roof-to-wall and other interfaces with various transition materials
- › Roof/ceiling penetrations
- › Window membrane and perimeter sealing
- › Above-grade to below-grade transitions
- › Complex building forms and enclosure shapes such as fin walls and projections
- › Late installation of service penetrations, after insulation or cladding is installed, and proper detailing can't be completed

These deficiencies can be avoided by using comprehensive detailing at the design stage, and employing proper quality control and assurance measures during construction.

**On-site quality control of air barrier installation is a complex process. It is fundamentally important to achieving an airtight building and requires substantial oversight.** The builder is ultimately responsible for ensuring all aspects of the system are installed and complete.

A successful approach to mitigate this risk is to designate an “air boss”, who is a member of the construction team responsible specifically for the air barrier. This person should be appropriately trained on and knowledgeable of air barrier strategies in general and the specific air barrier systems being used on the project. For more information on successful implementation of a high-performance air barrier system, refer to the *Illustrated Guide - Achieving Airtight Buildings* published by BC Housing.

## Typical Construction Details

The example details shown in the following pages are intended to establish a common level of detailing for the LEEP NZE Wall Assembly #1. Each guide in this series contains a similar set of details for their respective assembly.

### Using These Details

Builders are invited to replicate or modify these details, within the guidelines provided, to achieve the desired performance outcome. This may include Net Zero Energy (NZE) or other high-performance standards for light wood-framed construction.

We recognize that there are a multitude of high-performance wall assemblies. However, in regional LEEP initiatives, builder groups repeatedly asked to focus on these walls. LEEP worked with building science experts to evaluate these generic wall assemblies based on climate conditions, construction practices and local building codes. This guide series provides information, criteria and data that will help builders determine which of these generic types of high-performance wall assemblies are best suited to their needs.

The construction details illustrate transition strategies for air barrier, water-resistive barrier, and insulation continuity. The annotations and legend in each sample detail contains red “AB” and “AB/WRB” icons to indicate the various air barrier and, where applicable, water-resistive barrier components present. Note that these images are provided to illustrate improved best practices. To use these details in your project, modifications may be needed, including:

- › Creating additional details as required to address all elements of the specific project,
- › Selecting specific exterior cladding types and finishing systems in response to design requirements, including the related water management and fastening details,
- › Coordinating the wall assembly into the full scope of project specific systems and components such as: structural system, water management, mechanical and electrical systems, fire and life safety considerations, and
- › Producing specifications, certification or inspection as required by authorities having jurisdiction.

**Any modifications or additional details developed need to be carried out by those that have the experience and competency to do so. Minimum professional requirements vary by Province. To reduce the risk of post-installation deficiencies such as water penetration and mold, builders are encouraged to have details developed or reviewed by a building science engineer or architect.**

**Inexperienced crews should practice assembly installation and detailing work by building full-scale on-site mockups that can also be used for instruction and quality control (see also the [Builder Checklist for Net Zero Wall Construction on page 44](#)).**



Each unique project will require the development of specific details and construction documents to address the varied conditions found in each building and the local construction trade's capacity. In addition, each builder must provide quality control and assume liability for the work they complete. Reliable technical information and training are critical to your success. We recommend that builders take advantage of technical guides and training opportunities offered by credible sources and share this training with everyone on your crew. Work with your local Home Builders Association to find more information and to build local capacity.

For more guidance and example detailing for net zero energy wall assemblies, refer to the following additional resources:

- › BC Energy Step Code Builder Guide, BC Housing
- › Building Enclosure Design Guide, BC Housing
- › Guide for Designing Energy-Efficient Building Enclosures for Wood-Frame Multi-Unit Residential Buildings, FP Innovations, BC Housing, and the Canadian Wood Council
- › Illustrated Guide–R22+ Effective Walls in Wood Frame Construction in British Columbia, BC Housing

## List of Construction Details

Detail 1.01	Wall Section Overview & Materials . . . . .	34
Detail 1.02	Wall Section Details Wayfinder . . . . .	35
Detail 1.03	Base of Wall at Foundation . . . . .	36
Detail 1.04	Cladding Transition at Floor Line . . . . .	37
Detail 1.05	Wall & Roof Interface . . . . .	38
Detail 1.06	Window Sill . . . . .	39
Detail 1.07	Window Jamb . . . . .	40
Detail 1.08	Window Head . . . . .	41
Detail 1.09	Wall Penetration at Duct - Section . . . . .	42
Detail 1.10	Wall Penetrations at Receptacle - Section . . . . .	43

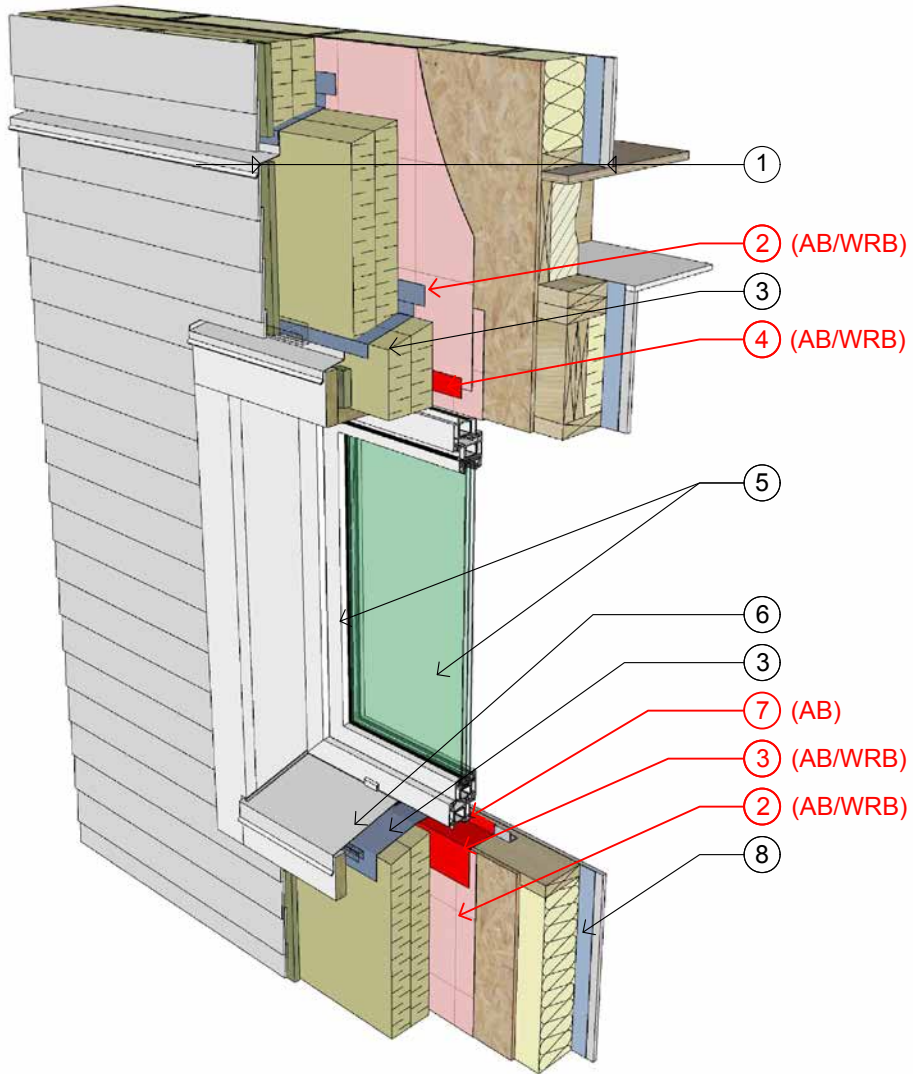

**LEGEND**

- ① Wall assembly, refer to split insulation details
- ② Mechanically attached vapour permeable sheathing membrane (AB/WRB)
- ③ Self adhesive membrane (AB/WRB)
- ④ Tape seal (AB/WRB)
- ⑤ Window, see Details 1.06 to 1.08 for installation
- ⑥ Pre-finished metal flashing
- ⑦ Window perimeter sealant (AB)
- ⑧ Vapour barrier membrane

**NOTE**

Refer to Appendix A for recommended products

**ABBREVIATIONS**

- AB → Air Barrier
- WRB → Water Resistant Barrier
- VB → Vapour Barrier
- VP → Vapour Permeable
- XPS → Extruded Polystyrene

**WALL SECTION OVERVIEW AND MATERIALS | D1.01**

Assembly #1 | Split-Wall: Vapour Permeable Exterior Insulation

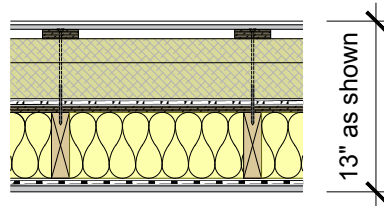
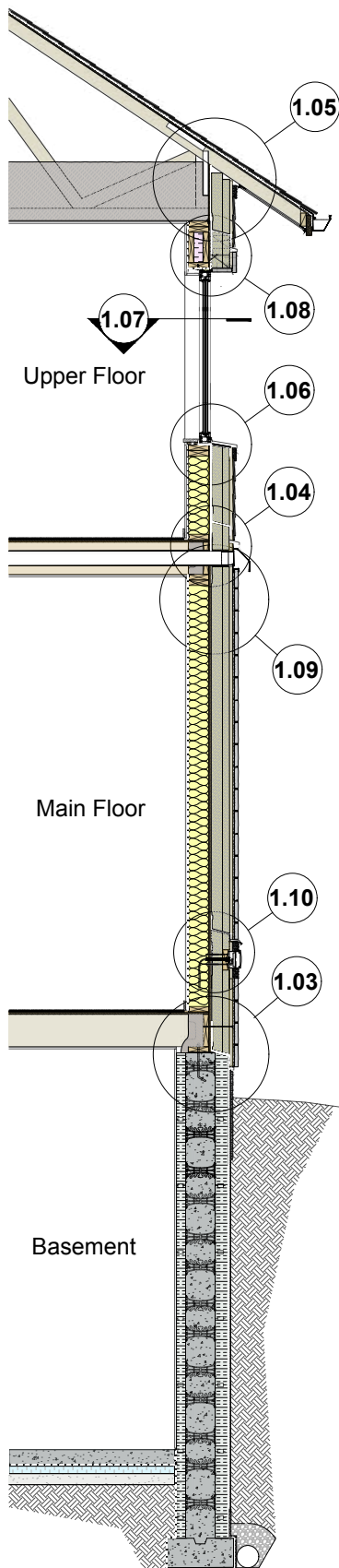

#### Wall Assembly at Fibre Cement Board Siding

- Fibre cement lap siding ( $\frac{3}{8}$ "
- Pressure treated wood strapping/air cavity ( $\frac{3}{4}$ "
- Rigid mineral wool exterior insulation (5" shown)
- Vapour permeable sheathing membrane (AB/WRB)
- Sheathing ( $\frac{1}{2}$ "
- 2x6 wood framing (5  $\frac{1}{2}$ "
- Batt insulation
- Vapour barrier membrane
- Interior gypsum wall board ( $\frac{1}{2}$ "

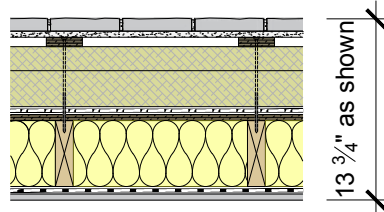

#### Wall Assembly at Thin Stone Veneer

- Thin stone veneer assembly c/w stucco base coat, wire lath and backer board (1  $\frac{1}{2}$ "
- Pressure treated wood strapping/air cavity ( $\frac{3}{4}$ "
- Rigid mineral wool exterior insulation (5" shown)
- Vapour permeable sheathing membrane (AB/WRB)
- Sheathing ( $\frac{1}{2}$ "
- 2x6 wood framing (5  $\frac{1}{2}$ "
- Batt insulation
- Vapour barrier membrane
- Interior gypsum wall board ( $\frac{1}{2}$ "

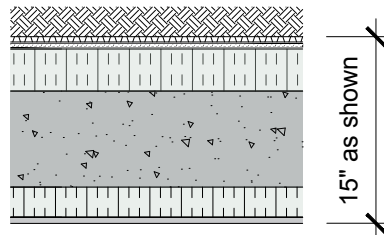

#### ICF Wall Assembly below Grade

- Concrete board (above grade)
- Exterior grade or soil (below grade)
- Plastic drain mat with integrated filter fabric ( $\frac{1}{2}$ "
- Below grade waterproofing membrane (AB/WRB)
- ICF Wall (14" shown)
- Interior gypsum wall board ( $\frac{1}{2}$ "

## WALL SECTION AND ASSEMBLIES | D1.02

Assembly #1 | Split-Wall: Vapour Permeable Exterior Insulation

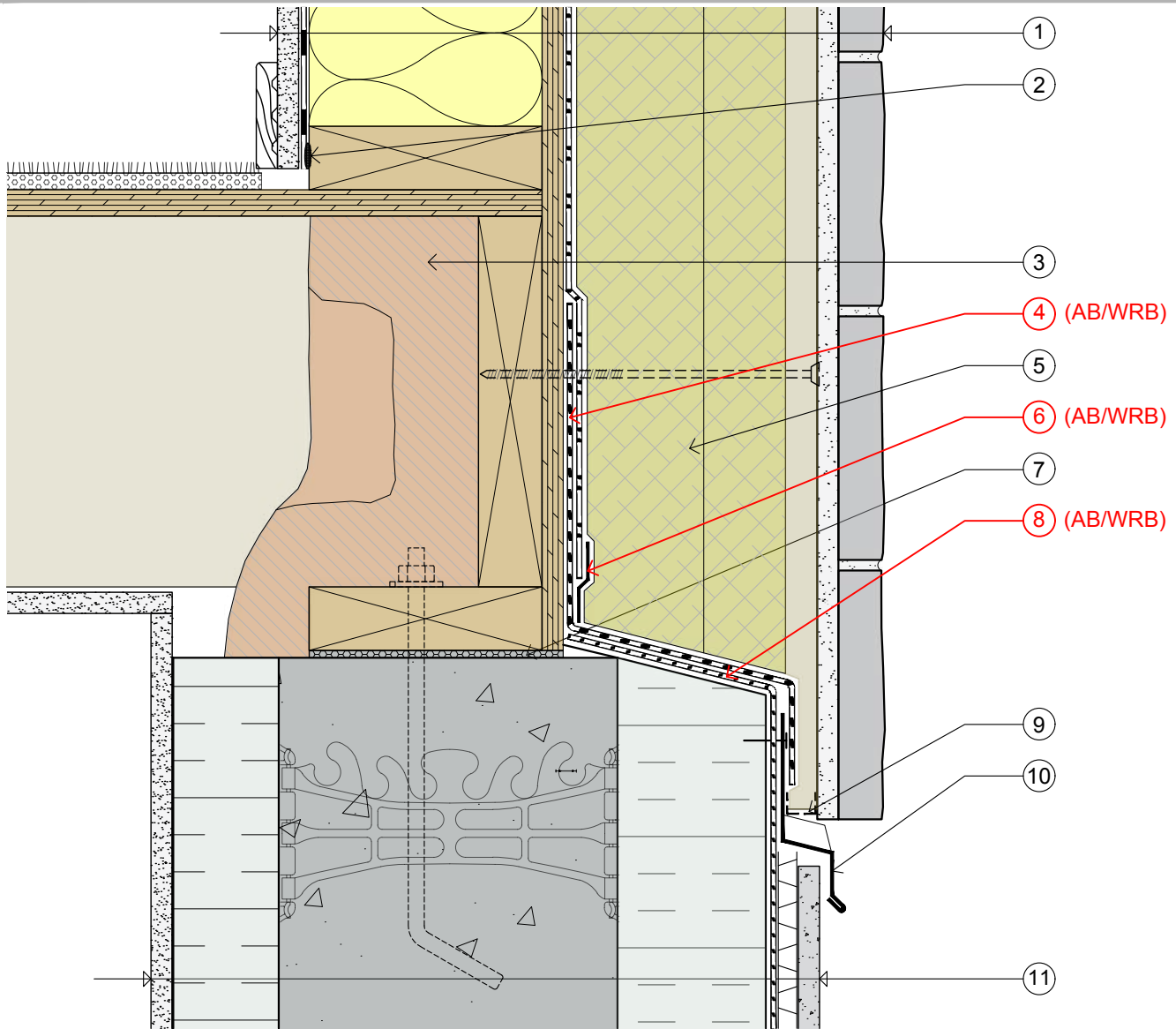

### LEGEND

- |   |  |
|---|--|
| <p>① Wall assembly</p> <ul style="list-style-type: none"> <li>• Thin stone veneer assembly c/w stucco base coat, wire lath and backer board</li> <li>• Pressure treated wood strapping/air cavity with blocking at fastener locations on studs and foam spacers between studs</li> <li>• Rigid mineral wool exterior insulation</li> <li>• VP sheathing membrane (AB/WRB)</li> <li>• Sheathing</li> <li>• 2x6 wood framing</li> <li>• Batt insulation</li> <li>• Vapour barrier membrane</li> <li>• Interior gypsum wall board</li> </ul> <p>② Sealant</p> <p>③ Continuous polyurethane spray foam insulation</p> | <p>④ Self adhesive membrane (AB/WRB)</p> <p>⑤ Rigid mineral wool exterior insulation</p> <p>⑥ Tape seal (AB/WRB)</p> <p>⑦ Foam gasket</p> <p>⑧ Below grade waterproofing membrane (AB/WRB)</p> <p>⑨ Insect screen</p> <p>⑩ Pre-finished metal flashing</p> <p>⑪ Wall assembly</p> <ul style="list-style-type: none"> <li>• Concrete board</li> <li>• Plastic drain mat with integrated filter fabric</li> <li>• Below grade waterproofing membrane (AB/WRB)</li> <li>• ICF wall</li> <li>• Interior gypsum wall board</li> </ul> |
|---|--|

## BASE OF WALL AT FOUNDATION | D1.03

Assembly #1 | Split-Wall: Vapour Permeable Exterior Insulation

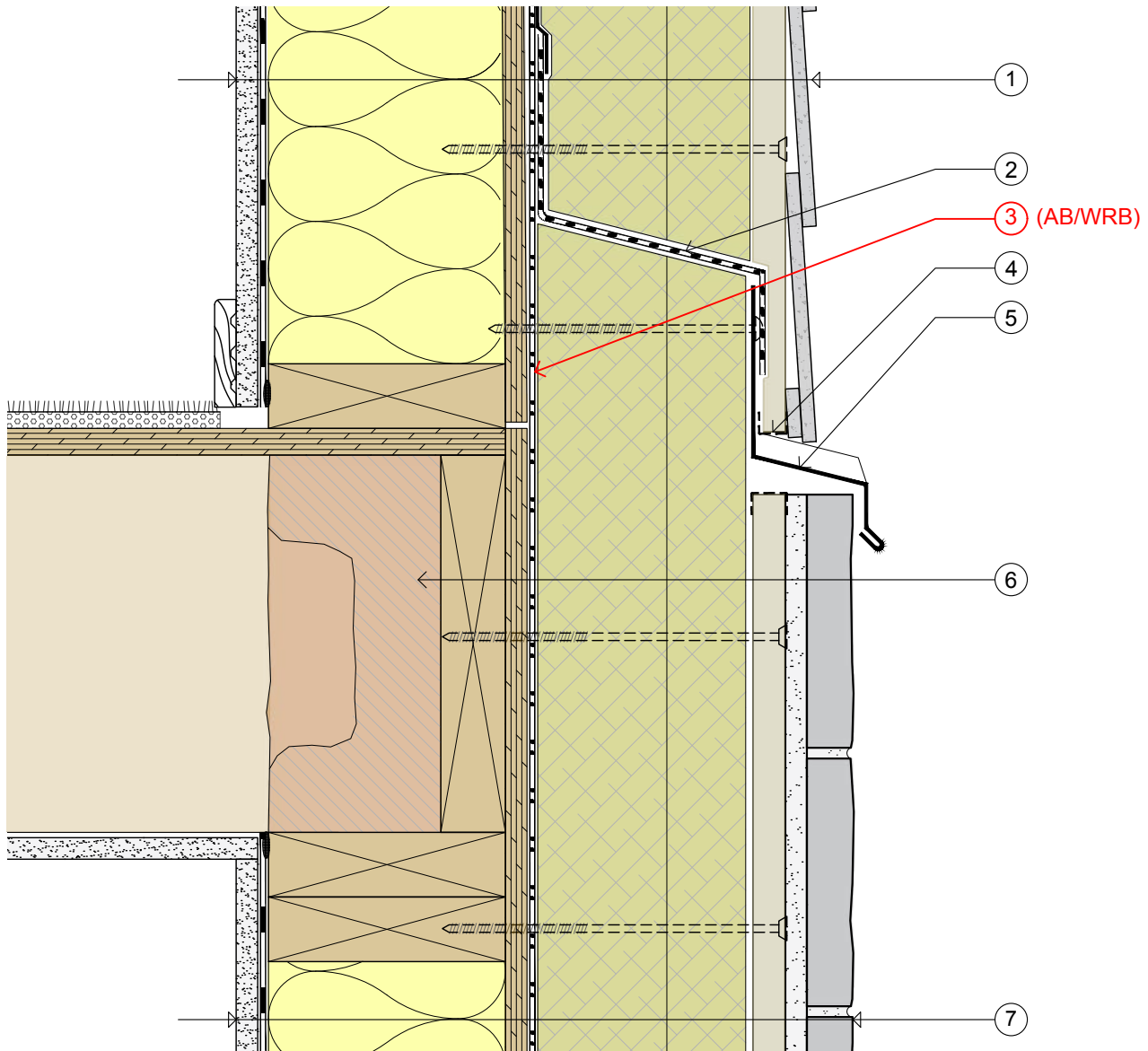

### LEGEND

- |  |   |
|--|---|
| <p>① Wall assembly</p> <ul style="list-style-type: none"> <li>• Fibre cement board siding</li> <li>• Pressure treated wood strapping/air cavity</li> <li>• Rigid mineral wool exterior insulation</li> <li>• VP sheathing membrane (AB/WRB)</li> <li>• Sheathing</li> <li>• 2x6 wood framing</li> <li>• Batt insulation</li> <li>• Vapour barrier membrane</li> <li>• Interior gypsum wall board</li> </ul> <p>② Self adhesive membrane</p> <p>③ VP sheathing membrane (AB/WRB)</p> <p>④ Insect screen</p> | <p>⑤ Pre-finished metal flashing</p> <p>⑥ Continuous polyurethane spray foam insulation</p> <p>⑦ Wall assembly</p> <ul style="list-style-type: none"> <li>• Thin stone veneer assembly c/w stucco base coat, wire lath and backer board</li> <li>• Pressure treated wood strapping/air cavity with blocking at fastener locations on studs and foam spacers between studs</li> <li>• Rigid mineral wool exterior insulation</li> <li>• VP sheathing membrane (AB/WRB)</li> <li>• Sheathing</li> <li>• 2x6 wood framing</li> <li>• Batt insulation</li> <li>• Vapour barrier membrane</li> <li>• Interior gypsum wall board</li> </ul> |
|--|---|

## CLADDING TRANSITION AT FLOOR LINE | D1.04

Assembly #1 | Split-Wall: Vapour Permeable Exterior Insulation

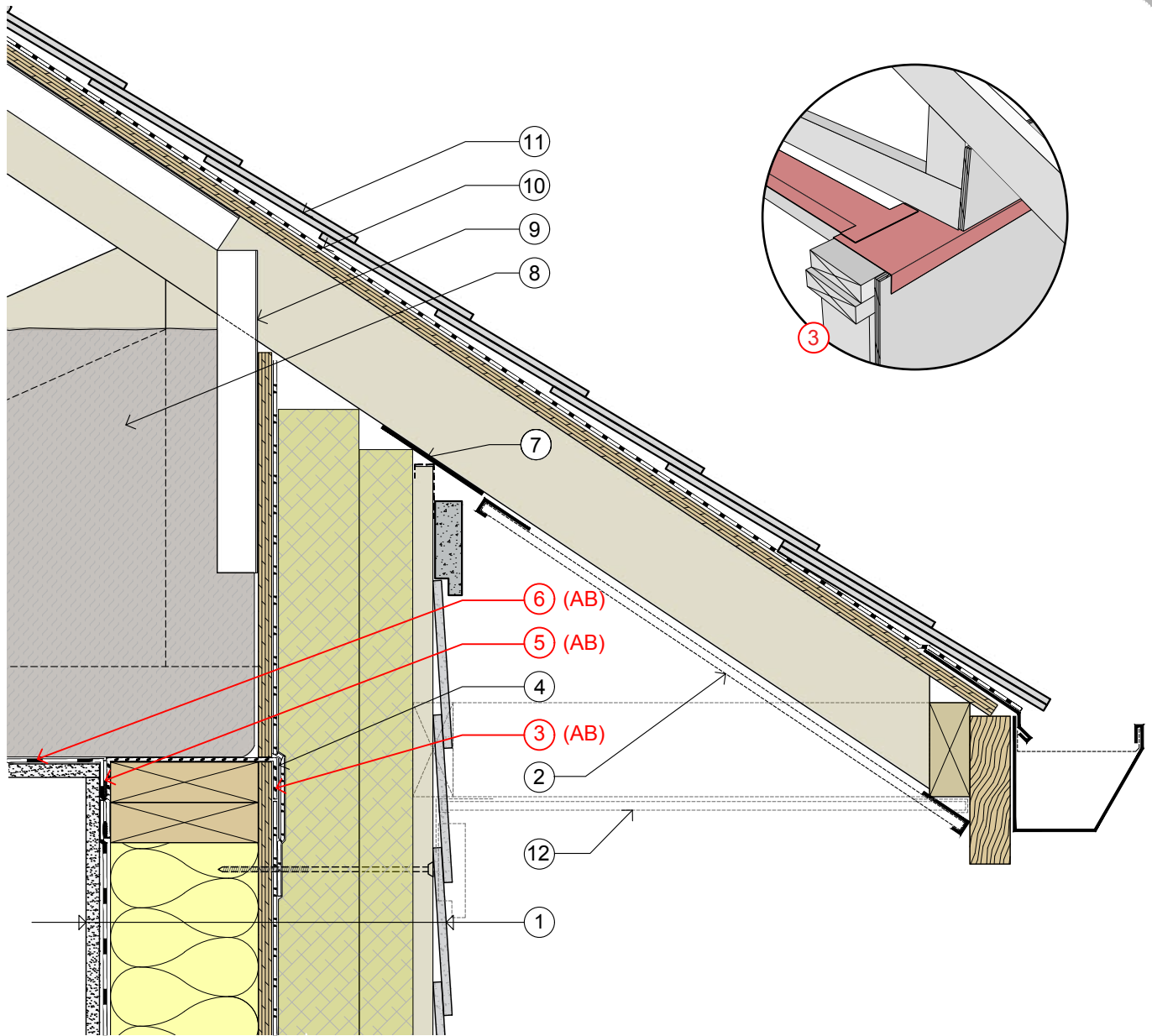

**LEGEND**

- |  |   |
|--|---|
| <p>① Wall assembly</p> <ul style="list-style-type: none"> <li>• Fibre cement board siding</li> <li>• Pressure treated wood strapping/air cavity</li> <li>• Rigid mineral wool exterior insulation</li> <li>• VP sheathing membrane (AB/WRB)</li> <li>• Sheathing</li> <li>• 2x6 wood framing</li> <li>• Batt insulation</li> <li>• Vapour barrier membrane</li> <li>• Interior gypsum wall board</li> </ul> <p>② Perforated soffit panel</p> <p>③ Continuous self adhesive membrane over all top plates (AB)</p> | <p>④ Continuous tape seal</p> <p>⑤ Continuous sealant at ceiling poly (AB)</p> <p>⑥ Ceiling poly (AB)</p> <p>⑦ Metal rainscreen closure flashing</p> <p>⑧ Cellulose insulation</p> <p>⑨ Vent &amp; insulation stop</p> <p>⑩ Roof underlayment including eave protection</p> <p>⑪ Roofing shingles</p> <p>⑫ Flat soffit approach</p> |
|--|---|

**WALL & ROOF INTERFACE | D1.05**

Assembly #1 | Split-Wall: Vapour Permeable Exterior Insulation

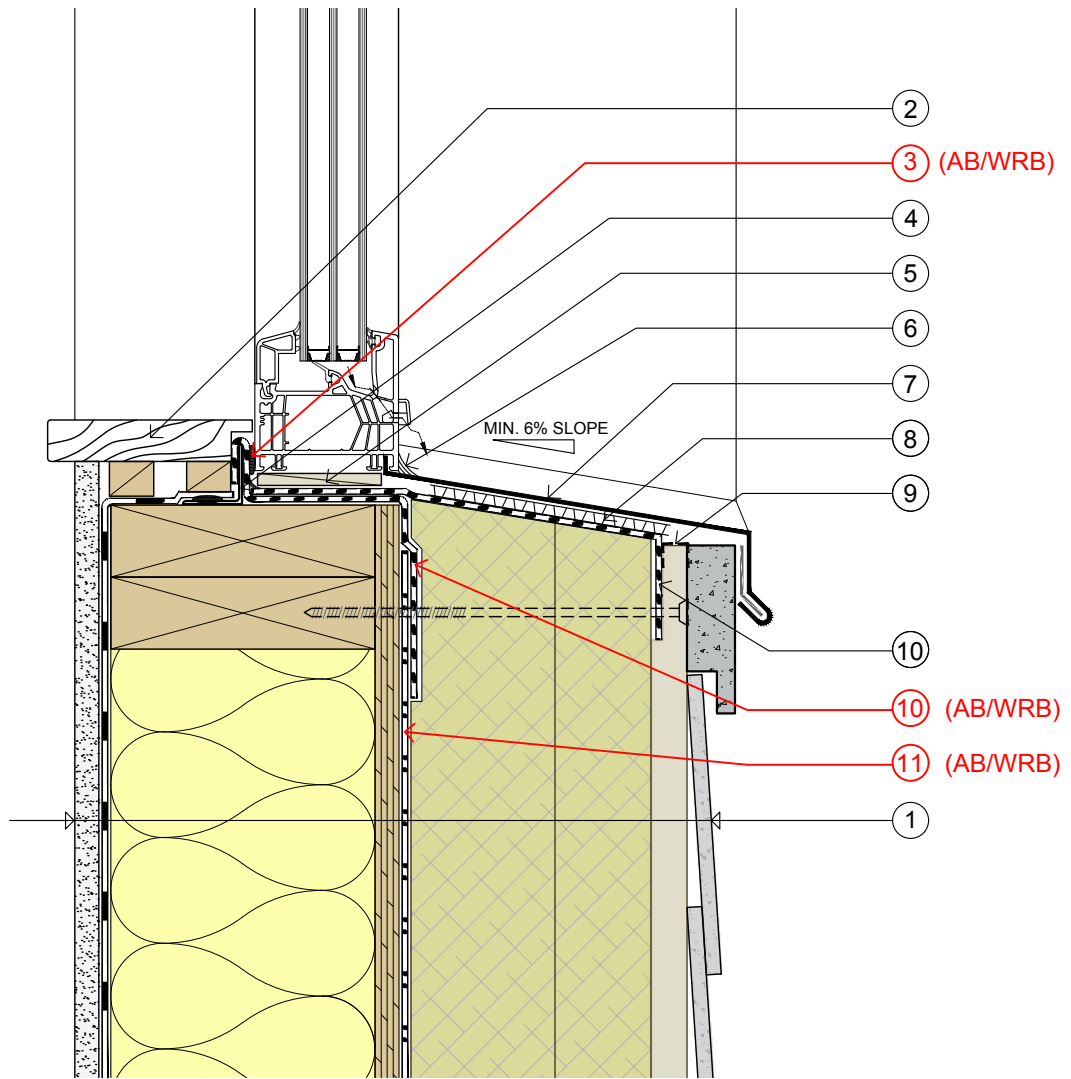

### LEGEND

- |   |   |
|---|---|
| <p>① Wall assembly</p> <ul style="list-style-type: none"> <li>• Fibre cement board siding</li> <li>• Pressure treated wood strapping/air cavity</li> <li>• Rigid mineral wool exterior insulation</li> <li>• VP sheathing membrane (AB/WRB)</li> <li>• Sheathing</li> <li>• 2x6 wood framing</li> <li>• Batt insulation</li> <li>• Vapour barrier membrane</li> <li>• Interior gypsum wall board</li> </ul> <p>② Interior window sill trim</p> <p>③ Continuous sealant (AB/WRB)</p> | <p>④ Continuous angle</p> <p>⑤ Intermittent shims</p> <p>⑥ Continuous sealant</p> <p>⑦ Pre-finished metal flashing c/w fastening cleat</p> <p>⑧ Drain mat</p> <p>⑨ Insect screen</p> <p>⑩ Self adhesive membrane (AB/WRB)</p> <p>⑪ VP sheathing membrane (AB/WRB)</p> |
|---|---|

## WINDOW SILL | D1.06

Assembly #1 | Split-Wall: Vapour Permeable Exterior Insulation

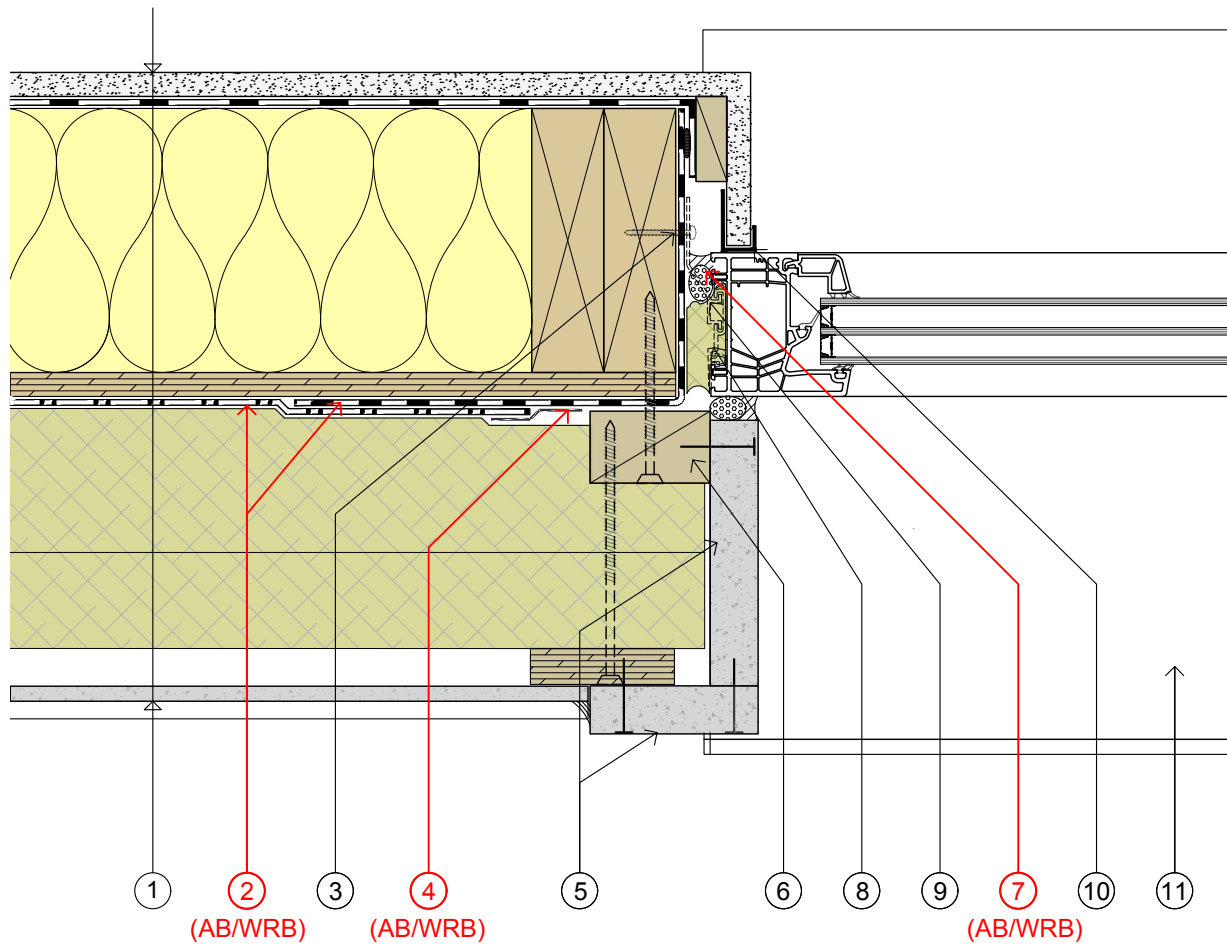

### LEGEND

- |  |  |
|--|--|
| <p>① Wall assembly</p> <ul style="list-style-type: none"> <li>• Fibre cement board siding</li> <li>• Pressure treated wood strapping/air cavity</li> <li>• Rigid mineral wool exterior insulation</li> <li>• VP sheathing membrane (AB/WRB)</li> <li>• Sheathing</li> <li>• 2x6 wood framing</li> <li>• Batt insulation</li> <li>• Vapour barrier membrane</li> <li>• Interior gypsum wall board</li> </ul> <p>② VP sheathing membrane (AB/WRB)</p> <p>③ Sealant</p> | <p>④ Tape seal (AB/WRB)</p> <p>⑤ Exterior trim</p> <p>⑥ Pressure treated wood blocking</p> <p>⑦ Backer rod &amp; sealant (AB/WRB)</p> <p>⑧ Insulation</p> <p>⑨ Intermittent fastening clip &amp; fastener</p> <p>⑩ J trim</p> <p>⑪ Pre-finished metal flashing</p> |
|--|--|

## WINDOW JAMB | D1.07

Assembly #1 | Split-Wall: Vapour Permeable Exterior Insulation



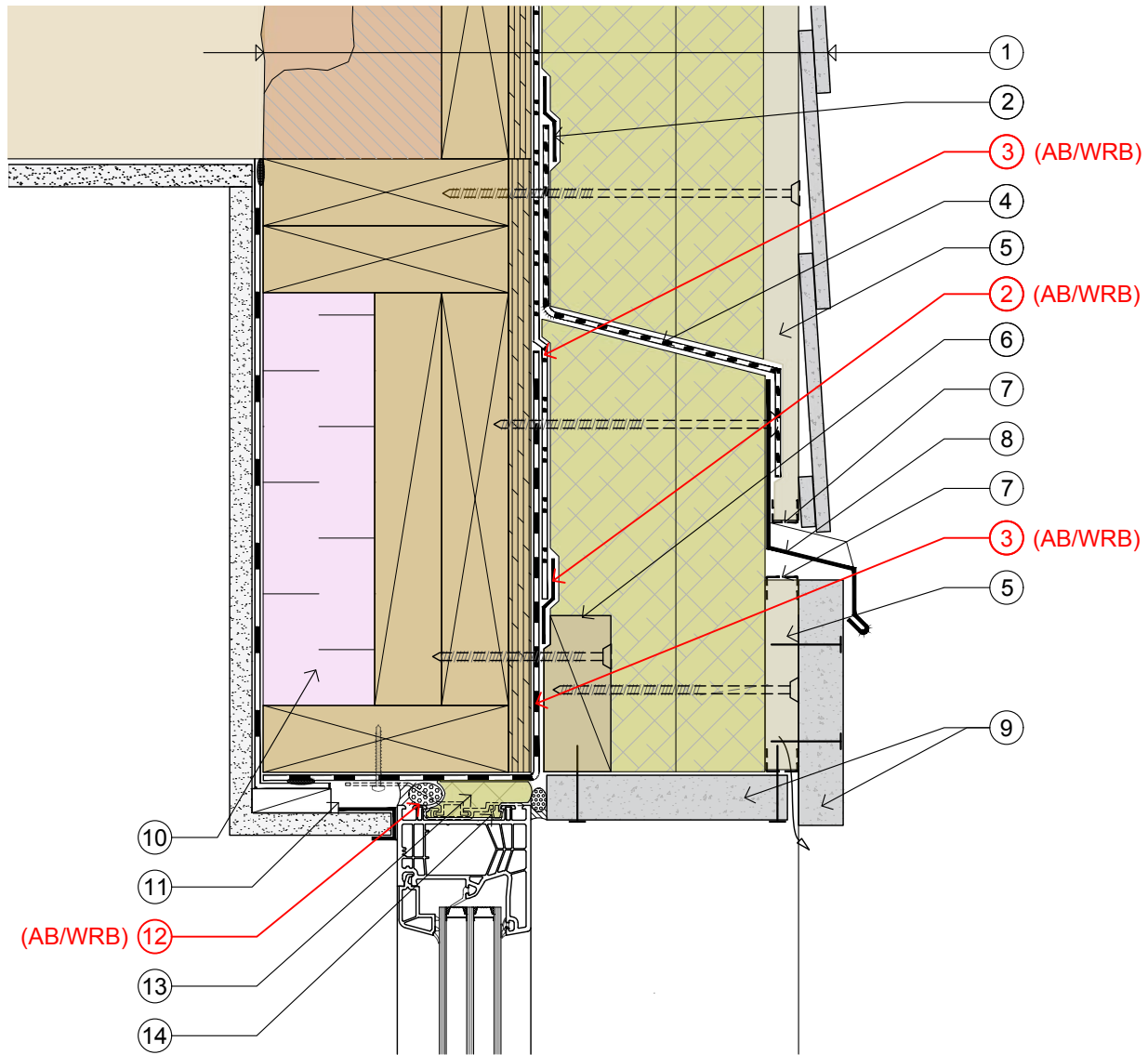

**LEGEND**

- |   |   |
|---|---|
| <p>① Wall assembly</p> <ul style="list-style-type: none"> <li>• Fibre cement board siding</li> <li>• Pressure treated wood strapping/air cavity</li> <li>• Rigid mineral wool exterior insulation</li> <li>• VP sheathing membrane (AB/WRB)</li> <li>• Sheathing</li> <li>• 2x6 wood framing</li> <li>• Batt insulation</li> <li>• Vapour barrier membrane</li> <li>• Interior gypsum wall board</li> </ul> <p>② Tape seal (AB/WRB)</p> <p>③ VP sheathing membrane (AB/WRB)</p> <p>④ Self adhesive membrane</p> <p>⑤ Pressure treated wood strapping/air cavity</p> | <p>⑥ Intermittent pressure treated 2x4 blocking</p> <p>⑦ Insect screen at top &amp; bottom</p> <p>⑧ Pre-finished metal flashing</p> <p>⑨ Exterior trim</p> <p>⑩ XPS insulation</p> <p>⑪ J trim</p> <p>⑫ Backer rod &amp; sealant (AB/WRB)</p> <p>⑬ Insulation</p> <p>⑭ Intermittent fastening clip &amp; fastener</p> |
|---|---|

**WINDOW HEAD | D1.08**

Assembly #1 | Split-Wall: Vapour Permeable Exterior Insulation

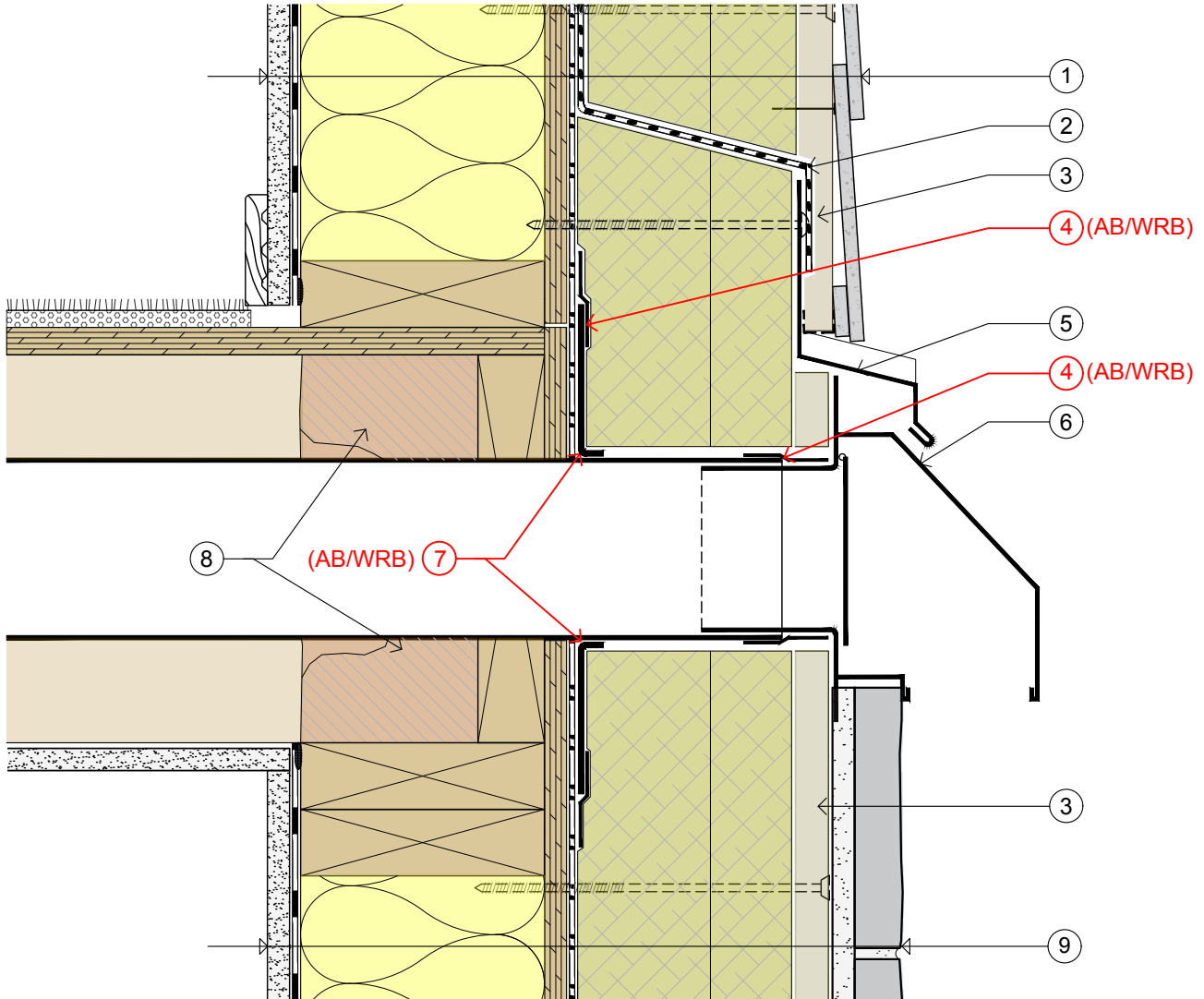

**LEGEND**

- ① Wall assembly
  - Fibre cement board siding
  - Pressure treated wood strapping/air cavity
  - Rigid mineral wool exterior insulation
  - VP sheathing membrane (AB/WRB)
  - Sheathing
  - 2x6 wood framing
  - Batt insulation
  - Vapour barrier membrane
  - Interior gypsum wall board
- ② Self adhesive membrane (WRB)
- ③ Pressure treated wood strapping/air cavity
- ④ Tape seal (AB/WRB)
- ⑤ Pre-finished metal flashing
- ⑥ Pre-finished metal vent hood with flange
- ⑦ EPDM patch with under-sized hole for gripping to duct perimeter (AB/WRB)
- ⑧ Fill void with polyurethane spray foam insulation
- ⑨ Wall assembly
  - Thin stone veneer assembly c/w stucco base coat, wire lath and backer board
  - Pressure treated wood strapping/air cavity with blocking at fastener locations on studs and foam spacers between studs
  - Semi rigid exterior insulation
  - VP sheathing membrane (AB/WRB)
  - Sheathing
  - 2x6 wood framing
  - Batt insulation
  - Vapour barrier membrane
  - Interior gypsum wall board

**WALL PENETRATION AT DUCT - SECTION | D1.09**

Assembly #1 | Split-Wall: Vapour Permeable Exterior Insulation

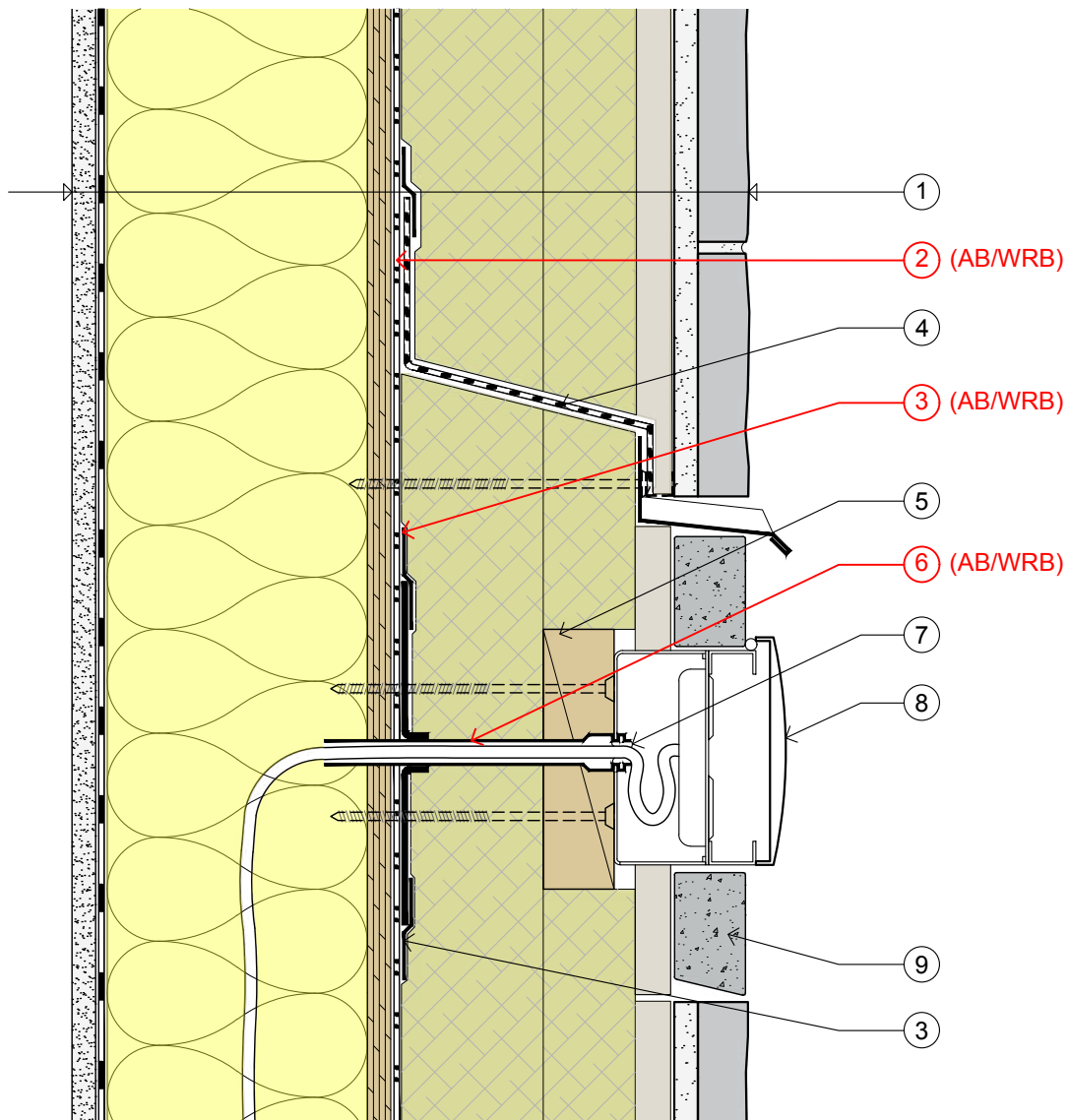

#### LEGEND

- |   |  |
|---|--|
| <p>① Wall assembly</p> <ul style="list-style-type: none"> <li>• Thin stone veneer assembly c/w stucco base coat, wire lath and backer board</li> <li>• Pressure treated wood strapping/air cavity with blocking at fastener locations on studs and foam spacers between studs</li> <li>• Rigid mineral wool exterior insulation</li> <li>• VP sheathing membrane (AB/WRB)</li> <li>• Sheathing</li> <li>• 2x6 wood framing</li> <li>• Batt insulation</li> <li>• Vapour barrier membrane</li> <li>• Interior gypsum wall board</li> </ul> | <p>③ Tape seal (AB/WRB)</p> <p>④ EPDM patch with under-sized hole for gripping to conduit perimeter (AB/WRB)</p> <p>⑤ Blocking</p> <p>⑥ Electrical conduit (AB/WRB)</p> <p>⑦ Cable sealed all around in conduit with moldable putty (AB/WRB)</p> <p>⑧ Exterior grade electrical outlet</p> <p>⑨ Trim board</p> |
| <p>② VP sheathing membrane (AB/WRB)</p>   |  |

## WALL PENETRATION AT RECEPTACLE - SECTION | D1.10

Assembly #1 | Split-Wall: Vapour Permeable Exterior Insulation

# Builder Checklist for Net Zero Wall Construction

Use the following builder checklist as a reference during the planning and construction phases.

☑	Pre-Design	Summary
☐	An Integrated Design Process (IDP) will benefit a project of any size. <b>IDP is a collaborative, team approach</b> to building design and construction. Gather your team and discuss options <b>before the design is completed</b> . Identify cross-over efficiencies and optimize for specific project goals. Put more effort up-front, by comparing options and using tools to measure and predict performance. IDP pays-off with better results, less risk, and predictable cost-to-benefit outcomes.	TEAMWORK & TOOLS
☐	<b>Discovery Meeting:</b> Invite key stakeholders to <b>define project goals</b> . Discuss labeling programs or incentives. Assess existing conditions and identify challenges and limitations. Identify priorities: must-have, wish-list and deal-breakers. Include: Owner, Builder, Designer, Energy Advisor, others as needed.	DEFINE GOALS
☐	<b>Target Building Performance:</b> Review code requirements and voluntary labelling programs. Select project goals for overall building performance (min. requirements or % better than code min. reference house) This will identify the <b>target range for the R-value of wall assemblies</b> . Record the project goals, refer back to them often and share them with everyone who joins the team.	SET PERFORMANCE TARGETS
☑	Design Development	
☐	Work with a <b>Licensed Designer or Technologist</b> to coordinate aesthetics, functional requirements and building systems. Prepare a draft design proposal that addresses all project goals.	DRAFT
☐	<b>Engage an Energy Advisor (EA) during schematic design.</b> Energy modeling will calculate the overall energy performance of your building compared to a generic 'typical' code minimum reference house. This becomes your 'benchmark' or baseline. Your Energy Advisor will confirm specific requirements or minimum standards for individual assembly or unit types. (Reference house is NBC 9.36 code minimum).	MEASURE
☐	<b>Select NZE Wall Assembly use criteria</b> starting with local climate zone and building code requirements. Consider other factors such as trade capacity, skills and experience, material cost and environmental impact. <b>Calculate effective R-values:</b> include insulation, cladding and framing variations, fasteners, and all other components. (Ask your EA or Designer about online calculators).	SELECT AND CALCULATE
☐	<b>Minimize Building Energy Loads:</b> Less energy required = less cost for Net Zero & more resilience. An 'Enclosure-First' approach uses high-performance walls to minimize the loss of expensive heated or cooled air. Coordinate all assembly types to create a continuous enclosure: foundation, walls, roofs, floors, doors, windows. Use details that show airtightness strategies at difficult transition points.  Use 'Passive Design' to your advantage: Consider the energy implications of building form, size, site orientation, solar heat gain, window to wall ratios, natural convection, exterior shading and cooling from vegetation and trees. These factors play a huge role in heating and cooling loads.	MINIMIZE ENERGY LOADS
☐	<b>Charrette:</b> Schedule this meeting well in advance. Ask all participants to prepare ahead. Hold a group, round-table discussion where all team-members, trades and consultants review draft plans, share ideas, compare options and optimize for the best outcome. Record important points and use this working session to make final decisions. Revise all drawing sets and complete the design proposal to clearly communicates these decisions.	OPTIMIZE AND FINALIZE

continues on next page

✓	<b>Construction Documents - Review</b>	<b>Summary</b>
☐	Wall Assembly Technical Review	REVIEW
	a. Integrate the selected wall assembly (building enclosure) into the structural system (load bearing components) of your building. These are separate systems but may be integrated in some locations. Confirm that each system and all components, framing and connections meet code requirements. Provide details for each critical and atypical condition.	ENCLOSURE & STRUCTURE
	b. WRB: Check that water management system allows water to shed off sloped surfaces and escape all cavities and has overlapped and properly layered 'water-resistive barriers' and/ or rainscreen systems.	WATER
	c. AB: Confirm 'continuous air barrier' across all transitions and between assembly and unit types. Check permeability based on wall assembly, particularly if air barrier is separate from the vapour control layer. Note this in your specifications and on your drawings. Confirm the correct and consistent use of flashing and sealants.	AIR
	d. VB: Confirm that there is only one vapour barrier in each assembly. Show this in wall sections. Check permeability based on wall assembly and climate zone. Note this in specifications and on your drawings.	VAPOUR
	e. Check condensation risk based on wall assembly materials, permeability, inboard to outboard insulation ratios and wall thickness. Confirm based on local climate and building code requirements. (See wall guides.)	CONDENSATION
	f. Reduce embodied carbon when selecting materials and look for 'low carbon' options. (Try online calculators like LEEP's MCE2). Consider life cycle and end-of-life cost. Ask questions about material source, manufacturing and transportation. Download and read EPDs (Environmental Product Declarations).	CARBON
☐	<b>Compliance and Verification:</b> Confirm compliance with local by-laws and construction regulations. Check for additional requirements beyond provincial code. Obtain required stamps, certification and additional documents required by voluntary labeling or incentive programs.	CHECK COMPLIANCE
☐	<b>Coordinate Building Systems:</b> Mechanical, electrical, and plumbing systems must be designed and sized correctly. Beware of rule-of-thumb solutions in high-performance, air-tight buildings. Consider both up-front cost and life-cycle costs. Peak energy loads determine equipment size and capacity so work to reduce loads first. Energy and heat recovery systems can also pay back by reducing waste and long-term cost.	COORDINATE MECHANICAL ELECTRICAL & PLUMBING
☐	<b>Construction Permit Application:</b> Confirm submission requirements and fees. Speak with the municipal plans examiner, review construction documents, wall assembly details, compliance package and discuss any deficiencies. Provide supporting information as requested.	APPLY

continues on next page

✓	Skills & Management	Summary
☐	<b>Pre-construction Team Meeting:</b> Clarify timeline and milestones. Review wall details and performance goals with the design and construction team (i.e., designer, EA, engineers, site supervisor, foundation co., framers, roofers, mason, all trades). Confirm start dates, sequencing, staging, lead-times. Always include contingency.	PLAN
☐	<b>Equip your crew for success:</b> Every crew member and all trades must clearly understand the project goals, the relevant construction documents and what you expect from them. Discuss any changes to typical practices and provide information when needed. Post details on the job site or give out copies to take home. Ask your crew to watch 'LEEP NZE Walls' construction training videos on the NRCAN YouTube Channel. Ask questions and discuss.	EQUIP & TEACH
☐	<b>Build a wall mock-up and test new assemblies and details:</b> Explain quality control expectations. Trial and discuss transition points, rim joist, wall-to-roof, doors & windows, wall thickness, cladding attachment, outboard insulation, continuous air barrier strategies, vapour barrier, and integration of water management and structural systems. Photograph mock-ups and details showing success and failure for future reference.	TEST & LEARN
☐	<b>Schedule air-tightness testing</b> (blower-door test) and designate an on-site 'Air Boss' to inform all trades and catch air-sealing errors. Request pre & post-drywall testing to provide preliminary feedback and allow time to seal leaks and gaps before the final test to verify performance.	ENFORCE & VERIFY

Notes and References:

- › The [Canadian Association of Consulting Energy Advisors](#) can direct you to a qualified Energy Advisor in your area.
- › [HVAC Designers of Canada](#) can help you find a qualified HVAC Designer in your area. Email: [info@hvacdc.ca](mailto:info@hvacdc.ca)
- › The [Canadian Homebuilders Association](#) (CHBA) and [LEEP](#) offer information and training opportunities. Ask your local home builders association to **request training or continuing-ed sessions** on Integrated Design (IDP), Costing, Carbon, wall systems, HVAC, more.
- › Watch NRCAN LEEP **videos**. Go to the [NaturalResourcesCa YouTube Channel](#). Search YouTube for “LEEP NZE Walls” or “Guides sur les murs nets zero”. NRCAN LEEP also offers videos and apps on HVAC design, Heat Pumps, and more.
- › [LEEP](#) offers online **guides, calculators, tools, and apps**: *LEEP NZE Wall Guide Series*, *Material Carbon Emissions Estimator* (MCE2), *Cost-Benefit Analysis Tool* (CBAT), HVAC guides, PV guides. Other industry tools calculate effective R-value or Solar Heat Gain conditions.
- › 'Performance Path' energy modeling often reveals cost and time-saving options. In addition, it provides verification of building performance to demonstrate **code compliance**. 'Prescriptive Path' compliance remains an option in most areas. Minimum performance requirements are determined by current Provincial building codes, energy codes, plus city or local regulations. Regional codes may reference the NBC but include variations. *EnerGuide* compares to 'typical' NBC 9.36 code minimum.
- › **Labeling programs** like *CHBA Net Zero Homes Program*, *LEED for Homes*, and *Passive House* share many objectives but vary in scope. Each program uses different metrics. Consult their websites for details or ask an EA, Architect, or Licensed Technologist to help.

# Notes

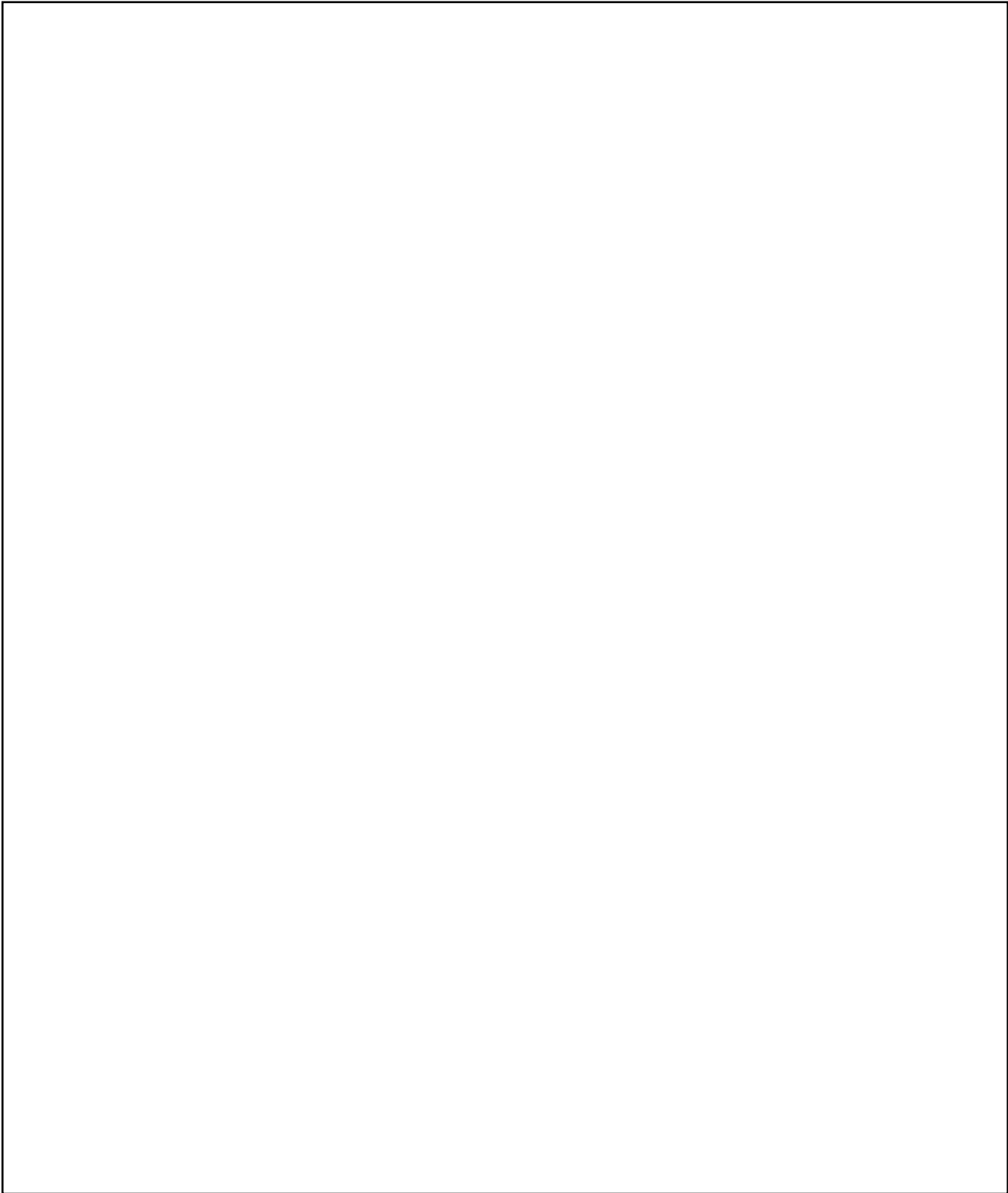



# LEEP

LOCAL ENERGY  
EFFICIENCY  
PARTNERSHIPS

Developed by Natural Resources Canada's Local Energy Efficiency Partnerships (LEEP) team  
LEEP Technology Guides and Tools available online. Search "NRCan LEEP".